



National Insurance Academy  
25, Balewadi, Baner Road, NIA P.O., Pune 411 045  
Tel: 020-27204000/4444, Fax: 020-27204555  
Website: [www.niapune.org.in](http://www.niapune.org.in)

**Through Online Mode Only**  
**NIA E-PROCUREMENT WEBSITE IS:**  
<https://www.tenderwizard.com/NIA>

---

**E-TENDER**



**Request for Proposal (RFP) for Design, Supply and Installation of AV  
Equipment for (Hybrid) Smart Classrooms at NIA, Pune.**

**Last date of submission of tender 21.08.2024 up to 15.00 Hrs**

### **DISCLAIMER:**

The information contained in this Tender document or subsequently provided to **Bidder(s)**, whether verbally or in documentary or any other form by National Insurance Academy (NIA) or any of their employees is provided to Bidder(s) on the terms and conditions set out in this Tender Document and such other terms and conditions subject to which such information is provided.

This Tender is not an agreement and is neither an offer nor invitation by the NIA to the Bidders or any other person. The purpose of this Tender is to provide interested parties with information that may be useful to them in making their technical and financial offers pursuant to this Tender (the "**Bid**"). This Tender includes statements, which reflect various assumptions and assessments arrived at by the NIA in relation to the Project. Such assumptions, assessments and statements do not purport to contain all the information that each Bidder may require. This Tender may not be appropriate for all persons, and it is not possible for the NIA, to consider the technical capabilities, investment objectives, financial situation and particular needs of each party who reads or uses this Tender. The assumptions, assessments, statements, and information contained in this Tender, may not be complete, accurate, adequate or correct.

Each Bidder should, therefore, conduct its own investigations, studies and analysis and should check the accuracy, adequacy, correctness, reliability and completeness of the assumptions, assessments, statements, and information contained in this Tender and obtain independent advice from appropriate sources.

Information provided in this Tender to the Bidder(s) is on a wide range of matters, some of which depends upon interpretation of law. The information given is not an exhaustive account of statutory requirements and should not be regarded as a complete or authoritative statement of law. NIA accepts no responsibility for the accuracy or otherwise for any interpretation or opinion on law expressed herein.

NIA, makes no representation or warranty and shall have no liability to any person, including any Bidder under any law, statute, rules or regulations or tort, principles of restitution or unjust enrichment or otherwise for any loss, damages, cost or expense which may arise from or be incurred or suffered on account of anything contained in this Tender or otherwise, including the accuracy, adequacy, correctness, completeness or reliability of the Tender and any assessment, assumption, statement or information contained therein or deemed to form part of this Tender or arising in any way in this Bid Stage. NIA also accepts no liability of any nature whether resulting from negligence or otherwise howsoever caused arising from reliance of any Bidder upon the statements contained in this Tender.

NIA may in its absolute discretion, but without being under any obligation to do so, update, amend or supplement the information, assessment or assumptions contained in this Tender. The issue of this Tender does not imply that NIA is bound to select a Bidder or to appoint the Preferred Bidder, as the case may be, for the Project and NIA reserves the right to reject all or any of the Bidders or Bids without assigning any reason whatsoever.

NIA reserves all the rights to cancel, terminate, change, or modify this selection process and/or requirements of bidding stated in the Tender, at any time without assigning any reason or providing any notice and without accepting any liability for the same.

The Bidder shall bear all its costs associated with or relating to the preparation and submission of its Bid including but not limited to preparation, copying, postage, delivery fees, expenses associated with any demonstrations or presentations which may be required by NIA, or any other costs incurred in connection with or relating to its Bid. All such costs and expenses will remain with the Bidder and NIA shall not be liable in any manner whatsoever for the same or for any other costs or other expenses incurred by a Bidder in preparation or submission of the Bid, regardless of the conduct or outcome of the Bidding Process.

\*\*\*\*\*

## **INFORMATION & INSTRUCTIONS TO THE BIDDERS**

### **FOR USING ONLINE ELECTRONIC TENDERING SYSTEM (ETS).**

Special Conditions & instructions for using online Electronic Tendering System (ETS) through portal (website) <https://www.tenderwizard.com/NIA> adopted by National Insurance Academy, Pune as given in the subsequent pages will over-rule the conditions stated in the tender documents, wherever relevant and applicable.

Bidders are required to enrol for Vendor Registration on the NIA e-Procurement Tender wizard Portal (URL: <https://www.tenderwizard.com/NIA> ) by clicking on the link “**Registration**” on the home page of e- Portal, which is chargeable. (Rs.1000/- + GST 18%, Non-Refundable) to be paid online through e-payment gateway). Those bidders who have enrolled recently need not register. The validity of registration is one year.

**Note:** The e-Payment Gateway is available on e-Procurement Portal for making the Online Vendor Registration Payment.

#### **Note: Information about e-Procurement Portal.**

More useful information for submitting online bids on the NIA e-Procurement Tender wizard Portal may be obtained at: <https://www.tenderwizard.com/NIA>.

Bidders are requested to refer to the Vendor’s manual by downloading the Vendor’s Manual by visiting on home page of <https://www.tenderwizard.com/NIA> and following KEY INSTRUCTIONS for BIDDERS by clicking on “Latest Circulars/Formats/Help Manuals/FAQs”. The complete Step by Step Vendors Help Manual For e-Procurement / e-Tendering Process, Vendors Registration Process, System Settings Requirements & JAVA Settings Manuals, e-Payment Guidelines & Digital Signature Certificate Process are available on e-Auction Website regarding the e-Auction.

Online Support / Web Support / E-Mail Support / Phone Support are also available for Bidders. Online support will be provided through “Team viewer” or “Ammy Admin” Remote software only.

For Downloading this software, the downloading software links are available on home page of e-Auction Website.

• **Registration of the Vendors / Bidders:** All the bidders intending to participate in the tenders floated online using Electronic Tendering System (ETS) are required to get registered on the e-Tender Portal (website) <http://www.tenderwizard.com/NIA>. After successful Registration on above mentioned portal, bidders will get a **User ID** and **Password** to access the website. Those bidders who have enrolled recently need not register. The validity of registration is one year.

• **Viewing of Online Tenders:** The bidders can view tenders floated on online Electronic Tendering System (ETS) hereinafter referred as “e-Tendering System” through portal (website) at <http://www.tenderwizard.com/NIA>. They can view the details like Tender Notice, Terms and

Conditions, drawing (if any) and any other information. To download the tender, they need to login on to the above portal and can download the tender documents of an e-Tender.

• **Key Dates:** The bidders can view the Online Scheduled dates of e-tendering System (time schedule) hereinafter referred as “Key Dates” for all the tenders floated using the online electronic tendering system on above mentioned portal (Website) <http://www.tenderwizard.com/NIA>

The bidders are strictly advised to follow dates and time as mentioned in Key Dates of a particular tender. The date and time will be binding on all the bidders. The bidders are required to complete the stages within the stipulated time as per the schedule (Key Dates) to continue their participation in the tender. All online activities are time tracked and the system enforces time locks that ensure that no activity or transaction can take place outside the start and end dates and time of the stage as defined. The bidder should ensure that the status of a particular stage should be shown as “**Completed**” before the expiry date and time of that particular stage and they should possess a copy of receipt of completion of each stage to be performed from their end which should match with the status with their offer on online portal. It will be the sole responsibility of the bidder if the status of a particular stage is “Pending” till the expiry date and time of that stage, and he will not be able to proceed further in the e-Tendering process. The Key dates are subject to change in case of any amendment in schedule due to any reason stated by the Department.

• **Obtaining a Digital Certificate and its Usage:** On e-Tendering System the bids should be Encrypted and Signed electronically with a Digital Signature Certificate (DSC) to establish the identity of the bidder on online Portal. The Digital Signature Certificate (DSC) has two keys i.e., Public Key and Private Key. The Public Key is used to Encrypt (code) the data and Private Key is used to decrypt (decode) the data. The Encryption means conversion of normal text into coded language whereas decryption means conversion of coded language into normal text.

**Note:** Digital Signature Certificates: Class III Signing + Encryption Digital Signature Certificate is required for e-Tendering. (DSCs) are issued by an approved Certifying Authority, by the Controller of Certifying Authorities (CCA India), Government of India.

• The bidders may obtain Class III digital certificate from any Certifying Authority or Sub certifying Authority authorized by the Controller of Certifying Authorities on the portal <http://cca.gov.in>. or may obtain information and application format and documents required for issue of digital certificate from our Service Provider for Electronic submission.

**E-Tendering System (ETS):**

E-Tender helpdesk, #24, Sudha Complex,  
03rd Stage, 04th Block, Basaveshwaranagara,  
Bengaluru - 560079  
dscprocessingunit@yahoo.com

**Help Desk Contact Details:**

Tel: 080-40482000/121/133/140, Mobile: 9686115304/9686115323

E-mail: [lokesh.hr@antaressystes.com](mailto:lokesh.hr@antaressystes.com) / [raghuprashanth@antaressystems.com](mailto:raghuprashanth@antaressystems.com)

- The Bid (Online Offer) for a particular e-Tender may be submitted only using the Digital Signature Certificate (DSC), which is used to Encrypt (codified) the data and sign the Hash (Impression of your data) during the stage of Bid Preparation and Hash submission. In case, during the process of a particular e-Tender, the user loses his Digital Certificate (i.e., due to virus attack, hardware problem, operating system problem), he may not be able to submit the bid online. Hence, the users are advised to keep their Digital Signature Certificates in safe custody.

- In case of online Electronic Tendering, if the Digital Certificate issued to the authorized user of a firm is used for signing and submitting an online bid, it will be considered equivalent to a no objection certificate/power of attorney to that User. The firm has to authorize a specific individual via an authorization certificate signed by all partners to use the Digital Certificate as per Indian Information Technology Act 2000 and its amendments. Unless the certificates are revoked, it will be assumed to represent adequate authority of the user to bid on behalf of agency for NIA Office Pune, as per Information Technology Act 2000 and its amendments. The Digital Signature of this authorized user will be binding on the firm. It shall be the responsibility of management / partners of the registered firms to inform the certifying authority or Sub Certifying Authority; in case of change of authorized user and that a fresh digital certificate is procured and issued an “Authorization Certificate” for the new user. The procedure for application of a Digital Certificate will remain the same for the new user.

- The same procedure holds true for the authorized users in a private/Public limited company. In this case, the authorization certificate will have to be signed by the directors of the company.

- Bidders participating in e-tendering shall check his/her validity of Digital Signature Certificate before bidding in the specific work floated online at the e-Tendering Portal (website) through <http://www.tenderwizard.com/NIA>.

**NOTE: -**

NIA AND TENDERWIZARD will not entertain any reasons /claims of Tenderer on account of Net Connection Failure/Power Connection Failure and any issues during the submission of tender online. Tenderer shall be solely responsible for all those facts and failure of Net Connectivity, Electricity Current Connectivity etc.

For Registration and for further details on e-tendering, please visit website above mentioned portal (website) or below mentioned address:

**E-Procurement Helpdesk Officials details.**

Office Address: - E-Tender helpdesk, # 24, Sudha Complex, 03rd Stage, 04th block, Basaveshwaranagara, Bangalore-560079

**Help Desk Contact Details: -**

- 1) **Mr. Sanjay K. Chandak, (Pune & Mumbai Maharashtra) (E-mail: [sanjay.kc@antaressystems.com](mailto:sanjay.kc@antaressystems.com)) Or [sanjay.kc@etenderwizard.com](mailto:sanjay.kc@etenderwizard.com) Ph: 9665721619.**
- 2) **Mr. Lokesh, (E-mail: [lokesh.hr@antaressystems.com](mailto:lokesh.hr@antaressystems.com)) Ph: 09686115304 & 080-40482140**

**RFP SCHEDULE:**

**Request for Proposal (RFP) for Design, Supply and Installation of AV Equipment for (Hybrid) Smart Classrooms at NIA, Pune.**

<b>Sl. No.</b>	<b>Items</b>	<b>Date &amp; Time</b>
1	Tender No.	NIA/ENGG/AV-010 dated 01.08.2024
2	Tender Type	Open
3	Availability of Tender Document on the website ( <a href="https://www.niapune.org.in">https://www.niapune.org.in</a> ) and for online participation visit the <a href="https://www.tenderwizard.com/NIA">https://www.tenderwizard.com/NIA</a> . only.	From 01/08/2024, 10.01 hrs. to 21/08/2024, 15.00 hrs.
4	Last date for receiving Pre-Bid queries.	10/08/2024 at 12.00 hrs.
5	Date and Time of Pre-bid Conference.	12/08/2024 at 15.00 hrs.
6	Inspection of Site / Location	From 01/08/2024 to 20/08/2024 during office hours 10.00 hrs. to 17.00 hrs. except Saturday / Sunday and Public Holidays
7	Issue of Corrigendum (if required)	On or before 14/08/2024
8	Last Date and Time for Submission of Bid Document	21/08/2024 up to 15:00 hrs.
9	Date and Time of opening of Pre-Qualification Bids & Technical Bids (PQ & TB)	22/08/2024 at 11.00 hrs.
10	Opening of Commercial Bid (CB) of qualified bidders.	To be informed later.
11	Tender Fee Applicable	Rs.1000.00 + GST
12	EMD Applicable	Rs.1,75,000.00

\*\*\*\*\*

## 1. Fact Sheet:

Clause Reference	Topic
<b>Commercial Bid Evaluation</b>	<p><b>The method of selection:</b> Least Cost Based Selection (LCBS) method will be used to select the Agency for <b>Design, Supply and Installation of AV Equipment for (Hybrid) Smart Classrooms at NIA, Pune.</b></p> <p>The bidder has to apply the bid in <b>two-part system</b>, Pre-Qualification – cum – Technical bid &amp; Financial bid. Financial bid of those bidders who qualifies in Pre-Qualification – cum – Technical bid shall be opened. The bidder with lowest- priced conforming (LPC) offer will be the most responsive bidder and will win the bid. <b>Consortium is not allowed for participation in the tender.</b></p>
<b>Downloading RFP Document</b>	RFP can be downloaded from <a href="https://niapune.org.in">https://niapune.org.in</a> and <a href="https://www.tenderwizard.com/NIA">https://www.tenderwizard.com/NIA</a>
<b>Registration Fee</b>	Tender Registration fee: One Time Tender Registration Fee in a year. Bidders are requested to pay the registration fee of <b>Rs. ₹1000/-+ GST</b> through online mode on <a href="https://www.tenderwizard.com/NIA">https://www.tenderwizard.com/NIA</a> portal. Those who have already registered need not have to pay Registration Fee.
<b>Tender Processing Fee</b>	Tender Processing fee: To participate in the bid, bidders are requested to pay the tender processing fee of <b>Rs. ₹1000/-+ GST</b> through online mode on <a href="https://www.tenderwizard.com/NIA">https://www.tenderwizard.com/NIA</a> portal.
<b>Scope of work</b>	This project is linked to deliverables relating to <b>Design, Supply and Installation of AV Equipment for Conversion of Lecture Hall 1 and 2 into (Hybrid) Smart Classrooms</b> and providing maintenance support within stipulated time.
<b>Language</b>	The Proposal should be filled up by the Bidder in English language only.
<b>Taxes</b>	Taxes: The bidder must quote price in Indian Rupees only. The bid price to be offered by the bidders must be inclusive of all taxes and levies <b>excluding GST</b> .
<b>Proposal Validity</b>	Proposals must remain valid till <b>180 days</b> after the last date of submission of the bids.
<b>Submission of Responses</b>	Bidders must submit all required documents online on the website <a href="https://www.tenderwizard.com/NIA">https://www.tenderwizard.com/NIA</a>
<b>Online Proposal</b>	This is an online proposal; interested bidders/parties are required to submit bids online only on the website mentioned in above clause. All required documents are to be uploaded and no hard copies will be entertained from the bidders.
<b>Last Date of Submission</b>	Proposals must be submitted not later than the following date and time: 21/08/2024 up to 15:00 hrs. or else the bid will be auto rejected by the portal / system.



<b>Submission of Document fee through Electronic Mode</b>	All payments of proposal will be done only through the tender wizard portal with multiple enabled payment options / modes. i.e., <a href="https://www.tenderwizard.com/NIA">https:// www.tenderwizard.com/NIA</a>
---	---

## **2. About the Institute:**

National Insurance Academy, Balewadi, Pune is an Apex Educational, Training and Research Institute in the field of Insurance, Pension and Management established under the aegis of Ministry of Finance, Government. of India and Public Sector Insurance Companies. The Director, NIA has requested **RFP for Design, Supply and Installation of AV Equipment for Conversion of Lecture Hall 1 and 2 into (Hybrid) Smart Classrooms.**

## **3. Instructions to the Bidders:**

### **3.1 General:**

- i. While every effort has been made to provide comprehensive and accurate, requirements, and specifications, Bidders must form their own conclusions about the requirements. Bidders and recipients of this RFP may wish to consult their own legal advisers in relation to this RFP.
- ii. All information to be supplied by Bidders will be treated as contractually binding on the Bidders, on successful award of the assignment by NIA on the basis of this RFP.
- iii. NIA reserves the rights to cancel this public procurement at any time without any notice and reason.
- iv. This RFP supersedes and replaces any previous public documentation & communications in this regard and Bidders should place no reliance on such communications.

### **3.2 Compliant Tenders / Completeness of Response:**

- i. Bidders are advised to study all instructions, forms, requirements, appendices, and other information in the RFP documents carefully. Submission of the bid / proposal shall be deemed to have been done after careful study and examination of the RFP document with full understanding of its implications.
- ii. Failure to comply with the requirements of this paragraph may render the Proposal non-compliant and the Proposal will be rejected.

#### **Bidders must:**

- a. Comply with all requirements as set out within this RFP.
- b. Submit the forms as specified in this RFP and respond to each element in the order as set out in this RFP.
- c. Include all supporting documentations specified in this RFP.

### **3.3 Pre-Bid Meeting & Clarifications:**

#### **3.3.1 Bidders Queries:**

- i. Pre-Bid Queries should be submitted in prescribed format before **10/08/2024** before **12.00 hrs**.
- ii. A pre-bid conference will be scheduled by NIA on **12/08/2024** at **14.00** hrs to clarify doubts of potential bidders in respect of the procurement and the records of such conference shall be published on the respective websites as Pre-bid clarifications.
- iii. Only the prospective bidders who have deposited the RFP document fees shall be allowed to participate in the Pre-bid meeting.
- iv. The RFP document fee of Rs.1000.00 + GST needs to be transferred online through NEFT/RTGS only to National Insurance Academy, Pune through the Payment Gateway of the website. In case of NEFT online transfer of RFP Document fee, the firm must mention the Firm Name, Amount Transferred with Transaction ID, Tender Enquiry Number, GST No through e-mail on **pvveer@niapune.org.in**.
- v. The Pre-bid meeting details shall be shared through the mail to the prospective bidders those have submitted the pre-bid queries along with proof of payment of RFP document fee.
- vi. The Bidders will have to ensure that their queries for Pre-Bid meeting should reach the below email id on or before the prescribed date as mentioned in "Important Dates and information" section of this RFP.
- vii. Pre-Bid Queries to be sent to **pvveer@niapune.org.in** with a copy to **amol@niapune.org.in** & **sridharjayashree@niapune.org.in**.
- viii. The Queries should necessarily be submitted in the format as prescribed in **Annexure-4** of this RFP.
- ix. NIA shall not be responsible for ensuring receipt of the bidder's queries. Any requests for clarifications post the indicated date and time may not be entertained by NIA.

#### **3.3.2 Responses to Pre-Bid Queries and Issue of Corrigendum:**

- i. NIA will endeavour to provide timely response to all valid queries. However, NIA makes no representation or warranty as to the completeness or accuracy of any response made in good faith, nor does NIA undertake to answer all the queries that have been posed by the bidders.
- ii. At any time prior to the last date for receipt of bids, NIA may, for any reason, modify the RFP Document by a corrigendum.
- iii. The Corrigendum (if any) & clarifications to the queries from all bidders will be posted on the websites: <https://www.niapune.org.in> and <https://www.tenderwizard.com/NIA> on 14/08/2024.
- iv. Any such corrigendum shall be deemed to be incorporated into this RFP.
- v. In order to provide prospective bidders reasonable time for taking the corrigendum into account, NIA may, at its discretion, extend the last date for the receipt of Proposals.

### **3.4 Key Requirements of the Bid:**

#### **3.4.1 Right to Terminate the Process:**

- i. NIA may terminate the RFP process at any time and without assigning any reason. NIA makes no commitments, express or implied, that this process will result in a business transaction with anyone.
- ii. This RFP does not constitute an offer by NIA. The bidder's participation in this process may result NIA selecting the bidder to engage towards execution of the contract.

- iii. NIA reserves the right to consider dropping any of the item asked for quotation in the RFP after evaluation of Technical Bid.

### 3.4.2 Bid Security (EMD):

The bidder should submit copies of Tender fee details (Rs.1000.00 + GST) and Earnest Money Deposit (Rs.1,75,000.00) details along with the bid. The tender fee and EMD details should be uploaded on or before the last date of submission of tender.

Bids without Tender Fee and EMD will be summarily rejected without any further reference to the bidder.

### 3.4.3 Submission of Responses:

- i. The bidders should submit their responses, as per the format given in this RFP in the following manner
  - Response to Pre-Qualification–cum–Technical Criteria: Online on the tender-wizard portal. <https://www.tenderwizard.com/NIA>
  - Commercial Proposal - Online on the tender-wizard portal. <https://www.tenderwizard.com/NIA>
- ii. All submission process will be done on the said (tender-wizard) portal only for any information or help you may refer the Help Manuals or Dial us on, **9665721619 / 9850130100** .
- iii. Please Note that Prices should not be indicated in the Pre-Qualification – cum - Technical Proposal but should only be indicated in the Commercial Proposal. Any Bidder found to indicate prices in the Pre-Qualification – cum - Technical Proposal are liable to be rejected.
- iv. All the pages of the proposal must be sequentially numbered and must contain the list of contents with page numbers. Page references should be identified easily. If required, All the relevant parts should be highlighted in the bid documents. Any deficiency in the documentation may result in the rejection of the Bid.
- v. Bidders may modify their prices till closing/submission date & time of this RFP in the prescribed excel format available on the tender-wizard portal and upload the scanned copies in the portal.
- vi. **Manufacturer Authorization Form (MAF) should be submitted positively in original/photocopies by the bidders while submitting the response to RFP, failing which the bid is subject to rejection. MAF is requested for following Equipment:**

SL. NO.	EQUIPMENT DETAILS	MAF REQUIRED
1	98” Ultra HD (4K) Interactive Display / 55” Ultra HD Display	√
2	Camera for Presenter / Students	√
3	Camera Mixer	√
4	Capture Card	√
5	Ceiling / Headworn / Lavalier / Handheld Microphones	√
6	12-Channel Mixing Console	√

7	DSP with AEC	√
8	On-Wall Powered Speakers	√
9	4 x 3 USB-C Matrix Switcher	√
10	HDMI Transmitter / Receiver	√
11	Customized Podium with Built in 21” Interactive Display and space for gooseneck microphone.	√
<b>OPTIONAL ITEMS</b>		
1	Sony 12X Camera for Presenter	√
2	Sony 30X Camera for Students	√

**vii. The Bidder(s) must submit the **Form-2 (Compliance Sheet for Technical Proposal)** in their official letterhead along with the Datasheet of the equipment quoted. Bidder(s) should upload the scanned copy in the portal**

#### **3.4.4 Authentication of Bids:**

A Proposal should be accompanied by a power-of-attorney / authorization in the name of the signatory of the Proposal. Bids shall be considered only on the successful bid submission on the tender-wizard portal.

#### **3.5 Preparation and Submission of Proposal:**

##### **3.5.1 Proposal Preparation Costs**

The bidder shall be responsible for all costs incurred in connection with participation in the RFP process, including, but not limited to, costs incurred in conduct of informative and other diligence activities, participation in meetings/discussions/presentations, preparation of proposal, in providing any additional information required by NIA to facilitate the evaluation process, and in negotiating a definitive contract or all such activities related to the bid process. NIA will in no case be responsible or liable for those costs, regardless of the conduct or outcome of the bidding process.

##### **3.5.2 Language:**

The Proposal should be filled by the bidders in English language only. If any supporting documents submitted are in any language other than English, translation of the same in English language is to be duly attested by the Bidders. For purposes of interpretation of the documents, the English translation shall govern.

##### **3.5.3 Venue & Deadline for Submission of proposals:**

Proposals, in its complete form in all respects as specified in the RFP, must be submitted to NIA at the website specified below:

<b>Website</b>	<a href="https://www.tenderwizard.com/NIA">https://www.tenderwizard.com/NIA</a>
<b>Last Date &amp; Time of Submission</b>	<b>21/08/2024 up to 15:00 hrs.</b>

### **3.5.4 Late Bids:**

- i. The bids submitted by telex/telegram/ fax/e-mail/post etc. shall not be considered. No correspondence will be entertained on this matter.
- ii. NIA reserves the right to modify and amend any of the above-stipulated condition/criterion depending upon project priorities and need.

### **3.6 Evaluation process:**

- i. A Committee constituted by NIA shall evaluate the responses to the RFP and all supporting documents / documentary evidence. Inability to submit requisite supporting documents / documentary evidence, may lead to rejection of bid.
- ii. The decision of the Committee in the evaluation of responses to the RFP shall be final. No correspondence will be entertained outside the process of evaluation with the Committee.
- iii. The above-mentioned Committee may ask for meetings with the Bidders to seek clarifications on their proposals.
- iv. The Committee reserves the right to reject any or all proposals on the basis of any deviations.
- v. Each of the responses shall be evaluated as per the criteria and requirements specified in this RFP.
- vi. Clarification (if any) sought has to be submitted by the bidder within specified timeline, failing which the Bid is liable to be rejected.

#### **3.6.1 Tender Opening:**

The Proposals **PQ & TQ** submitted up to **21/08/2024 up to 15:00 hrs.** will be opened at **11:00 AM on 22/08/2024** online.

#### **3.6.2 Tender Validity:**

The offer submitted by the Bidders shall be valid for minimum period of **180 days** from the last date of submission of Tender.

#### **3.6.3 Tender Evaluation:**

- i. Incomplete details as given below will be treated as non-responsive. If Proposals:
  - Are not submitted in as specified in the RFP document
  - Received without the Letter of Authorization/Power of Attorney
  - Are found with suppression of details
  
  - With incomplete information, subjective, conditional offers and partial offers submitted
  - Submitted without the documents requested in the checklist
  - Have non-compliance of any of the clauses stipulated in the RFP
  - With lesser validity period
- ii. All responsive Bids will be considered for further processing as below.
  - NIA will prepare a list of responsive/eligible bidders, who comply with all the Terms and Conditions of the Tender. All eligible bids will be considered for further

evaluation by the Committee according to the Evaluation process defined in this RFP document. The decision of the Committee will be final in this regard.

#### **4. Criteria for Evaluation**

##### **4.1. Pre-Qualification (PQ) – Cum- Technical Criteria**

All bids will primarily be evaluated on the basis of Prequalification Criteria- Cum-Technical Bid.

The Committee will carry out a detailed evaluation of the Proposals. Only those bidders who qualify all Prequalification & Technical criteria, are eligible for opening of their Financial Bid.

**Bidder shall quote for all the items including Optional Items. The order will be placed on turnkey basis only and will not be bifurcated / splitted, in any case.**

**Bidder shall quote only for one brand for each item. Multiple brands quoted may disqualify the bidder from the process.**

<b>Sl. No.</b>	<b>Basic Requirement</b>	<b>Specific Requirements</b>	<b>Documents Required</b>
1.	Legal Entity	The bidder should be a Company registered under the Companies Act, 1956 / Proprietary Firm / Partnership Firm under the Partnership Act 1932. The company offices must have been Registered in Maharashtra, Registered with Valid GST No and having PAN, & IT Return up to 31 <sup>st</sup> March 2023/24.	– Certificates of incorporation. – Registration Certificates, – PAN copy & other necessary supporting documents.
2.	Average Sales Turnover in AV Hardware and Software Sales & Maintenance Services.	<b>Annual Average Turnover</b> of Minimum of <b>₹ 100 Lakhs</b> generated from Supply and Installation of Projectors / Interactive / LED Displays / Videowalls / Sound Systems and associated maintenance services during <b>any three last financial years</b> i.e.: FY 23-24, FY 22-23, FY 21-22, FY 20-21, FY -2019-20 and FY 2018-19	Extracts from the audited Balancesheet and Profit & Loss: OR Certificate from the statutory auditor
3.	Net Worth	The net worth of the bidder in the last three financial years should be positive.	CA Certificate with CA's Registration Number / Seal indicating net worth of the firm.
4.	i. Technical Capability	The Bidder must be <b>AV System Integrator</b> and should be in the field of providing Audio Visual Solutions and should be in operations in India for at least Five Years as on 31-Mar-	Technical Capability: Work order along with Completion Certificates from the client / duly signed, Delivery

		<p>2024. Past experience certificate or Orders would be required for the same.</p> <p>Bidder must have successfully undertaken / completed at least the following numbers of Audio-Visual installations and associated maintenance services specified herein during the last five financial years, ending on the last date of submission of the bid:</p> <p>One project of similar nature not less than the amount <b>Rs. 64 Lakhs.</b>  <b>OR</b>  Two projects of similar nature each of which not less than the amount <b>Rs. 40 Lakh.</b>  <b>OR</b>  Three projects of similar nature each of which not less than the amount <b>Rs. 32 Lakh.</b></p> <p>'Similar Nature' is defined as Design, Supply, installation, and maintenance of AV equipment like projectors, interactive / led displays, VC units, videowalls, active led walls, sound systems / smart classroom projects and associated maintenance services for government / public / private sector enterprises in India and Government and Private Institutes.</p> <p><b>Note: Please note that the firms which are primarily dealing in computer hardware and software supplies will not be considered and their tender is liable to be rejected even if they meet other eligibility criterion.</b></p>	<p>Challan and Installation Report need to be submitted.  Project should be complete in all respect.</p>
	ii. Technical Capability	<p>The bidder must have Tender Specific Authorization stating that quoted products are not end of sales or discontinued, from the manufacturer for Supply, installation, support, and services of the OEM. <b>The Bidder must attach Tender Specific Authorization certificates from all the OEMs.</b></p>	
5	Local Service Centers	<p>The bidder should have presence in Maharashtra with Service Support Center at Pune / Mumbai.</p>	<p>– A Self Certified letter by an authorized signatory.</p>

			– A single point of Contact from the bidder to be submitted along with escalation matrix.
6	Blacklisting	The bidder must not have been blacklisted by any Department of Government of Maharashtra or Government of India. The bidder must also disclose full details of any blacklisting by Central or State PSUs / Undertakings / Autonomous Organizations or under a declaration of ineligibility for corrupt or fraudulent practices in last two years ‘as on’ <b>31/03/2024</b> .	A Self certified letter by an authorized signatory.
7	Performance	The Bidder must not have any record of poor performance, abandoned work, having inordinately delayed completion, and having faced commercial failures etc. for any State Government or Government of India Organization / Department during last 5 years as on ‘ <b>31/03/2024</b> ’.	A Self certified letter

#### 4.2. Commercial Bid Evaluation:

- The Financial Bids of PQ and technically qualified bidders will be opened online on the prescribed date.
- The Bidder who submits the lowest Commercial bid, shall be selected as the **L1 bidder**, and shall be called for further process leading to the award of the assignment.
- The rates quoted must be FOR destination / site where the AV Hardware and peripherals are to be delivered and should include all incidental charges.
- Only fixed price financial bids indicating total prices for all the deliverables and services specified in this bid document will be considered.
- The bid price will include all taxes and levies excluding GST and shall be in Indian Rupees.
- Prices quoted in the bid must be firm and final and shall not be subject to any modifications, on any account whatsoever.
- All the required items must be listed and priced separately in the financial bid. If a financial bid shows items listed but not priced, their prices shall be assumed to be included in the prices of



other items.

- An evaluation will be made on the basis of total bid price inclusive of all taxes. The bidder has to quote Tax(s) as applicable in the Tax Columns of Financial Bid Format. Evaluation will be done on the basis of Grand Total cost [Total cost = (Unit cost + Taxes as applicable)].
- In case of a Tie of the bid price for L1, both the bidders shall be called for further negotiations, then whose ever price becomes L1 will be awarded the contract.
- Any conditional commercial bid would be rejected.
- Errors & Rectification: Arithmetical errors will be rectified on the following basis: “If there is a discrepancy between the unit price and the total price of any item that is obtained by multiplying the unit price and quantity, the unit price shall prevail and the total price shall be corrected accordingly. In case of multiple items, grand total price shall be corrected adding the sub-total costs of each item. If there is a discrepancy between words and figures in respect of unit price, the amount in words will prevail”.

## **5. Appointment of AV Integrator [Hardware & Peripherals Supplier]**

### **5.1 Award Criteria**

NIA will award the Contract to the successful bidder whose proposal is determined to be substantially responsive as per the process outlined above.

### **5.2 Right to Accept Any Proposal and To Reject Any or All Proposal(s)**

NIA reserves the right to accept or reject any proposal, and to annul the tendering process / Public procurement process and reject all proposals at any time prior to award of contract, without thereby incurring any liability to the affected bidder or bidders or any obligation to inform the affected bidder or bidders of the grounds for NIA action.

### **5.3 Notification of Award**

Prior to the expiration of the validity period, NIA will notify the successful bidder through tender-wizard portal as also through e-mail, that its proposal has been accepted. In case the tendering process / public procurement process has not been completed within the stipulated period, NIA, may like to request the bidders to extend the validity period of the bid.

The notification of award will constitute the formation of the contract. Upon the successful bidder furnishing Performance Bank Guarantee, NIA will notify each unsuccessful bidder.

### **5.4 Performance Bank Guarantee (PBG)**

- i. The selected bidder will submit a Performance Bank Guarantee (PBG), within **10 days** after issuance of Purchase order or Work order issued by NIA, for a value equivalent to **5%** of the total order value. No MSME registration will be considered for availing exemption in tender fee, EMD and PBG.
- ii. The Performance Bank Guarantee needs to be furnished for Total validity period of **36 months + 3 months claim period** from the date of submission of PBG. The selected bidder

shall be responsible for claim period of the Performance Guarantee as and when it is due on account of non- completion of the project and Warranty period.

- iii. In case the selected bidder fails to submit performance Bank guarantee within the time stipulated, NIA at its discretion may cancel the order placed on the selected bidder without giving any notice and may suspend the bidder for a specific period of time as decided by the committee.
- iv. In that event, NIA, at its discretion, may award the Contract to the next best value bidder with the discovered L1 Price, in case the bidder is agreed and whose offer is valid.
- v. NIA shall invoke the performance Bank Guarantee in case the selected Vendor fails to discharge their contractual obligations during the project period or NIA incurs any loss due to Vendor's negligence in carrying out the project implementation as per the agreed terms & conditions.
- vi. Performance Bank Guarantee shall be returned after 1 month of warranty period completion.
- vii. No interest will be paid by NIA on the amount of performance Bank Guarantee.
- viii. EMD of the successful bidder will be refunded within a month after submission of Performance Bank Guarantee.

### **5.5 Failure to Agree with the Terms and Conditions of the RFP**

Failure of the successful bidder to agree with the Terms & Conditions of the RFP shall constitute sufficient grounds for the annulment of the award, in which event NIA may award the contract to the next best value bidder or call for new proposals from the interested bidders. In such a case, NIA shall invoke the PBG of the bidder.

## **6. Fraudulent and Corrupt Practices**

- i. The Bidders and their respective officers, employees, agents, and advisers shall observe the highest standard of ethics during the Selection Process. Notwithstanding anything to the contrary contained in this RFP, NIA shall reject a Proposal without being liable in any manner whatsoever to the Bidder, if it determines that the Bidder has, directly or indirectly or through an agent, engaged in corrupt practice, fraudulent practice, coercive practice, undesirable practice, or restrictive practice (collectively the "Prohibited Practices") in the Selection Process. In such an event, NIA shall, without prejudice to its any other rights or remedies, forfeit and appropriate Performance Security or suspend the bidder for a specific time period, as the case may be, as mutually agreed genuine pre-estimated compensation and damages payable to the Authority for, inter alia, time, cost and effort of the Authority, in regard to the RFP, including consideration and evaluation of such Bidder's Proposal.
- ii. Without prejudice to the rights of NIA under Clause above and the rights and remedies which NIA may have under the LOI or the Agreement, if a Bidder is found by NIA to have directly or indirectly or through an agent, engaged or indulged in any corrupt practice, fraudulent practice, coercive practice, undesirable practice or restrictive practice during the Selection Process, or after the issue of the Work Order or the execution of the Agreement, such Bidder shall not be eligible to participate in any tender or RFP issued by NIA during a period of 2 (two) years from the date of such Bid.
- iii. For the purposes of this Section, the following terms shall have the meaning hereinafter respectively assigned to them:

- a. “corrupt practice” means (i) the offering, giving, receiving, or soliciting, directly or indirectly, of anything of value to influence the action of any person connected with the Selection Process (for avoidance of doubt, offering of employment to or employing or engaging in any manner whatsoever, directly or indirectly, any official of NIA who is or has been associated in any manner, directly or indirectly with the Selection Process.
- b. “fraudulent practice” means a misrepresentation or omission of facts or disclosure of incomplete facts, in order to influence the Selection Process.
- c. “coercive practice” means impairing or harming or threatening to impair or harm, directly or indirectly, any persons or property to influence any person’s participation or action in the Selection Process.
- d. “undesirable practice” means (i) establishing contact with any person connected with or employed or engaged by NIA with the objective of canvassing, lobbying or in any manner influencing or attempting to influence the Selection Process; or (ii) having a Conflict of Interest; and
- e. “Restrictive Practice” means forming a cartel or arriving at any understanding or arrangement among Bidders with the objective of restricting or manipulating a full and fair competition in the Selection Process.

## **7. Conflict of Interest:**

The bidder shall disclose to NIA in writing, all actual and potential conflicts of interest that exist, arise or may arise in the course of performing the Service(s) as soon as practical after it becomes aware of that conflict.

- i. NIA considers a conflict of interest to be a situation in which a party has interests that could improperly influence that party’s performance of official duties or responsibilities, contractual obligations, or compliance with applicable laws and regulations. In pursuance of NIA's Procurement Ethics requirement that bidders, suppliers, and contractors under contracts, observe the highest standard of ethics, NIA will take appropriate actions against the bidder(s), if it determines that a conflict of interest has flawed the integrity of any procurement process. Consequently, all bidders found to have a conflict of interest shall be disqualified.
- ii. A bidder may be considered to be in a conflict of interest if the bidder or any of its affiliates participated as a consultant in the preparation of the solicitation documents/RFP for the procurement of the goods and services that are the subject matter of the bid.
- iii. It may be considered to be in a conflict of interest with one or more parties in the bidding process if
  - a. they have controlling shareholders in common; or
  - b. it receives or have received any direct or indirect subsidy from any of them; or
  - c. they have the same legal representative for purposes of the Bid; or
  - d. they have a relationship with each other, directly or through common third parties, that puts them in a position to have access to information about or influence on the Bid of another Bidder or influence the decisions of the tendering authority regarding this bidding process.

## **8. Terms and Conditions: Applicable Post Award of Contract**

### **8.1 Termination Clause**

#### **8.1.1 Right to Terminate the Process**

NIA reserves the right to cancel the contract placed on the selected bidder and recover expenditure incurred by NIA under the following circumstances:

- i. The selected bidder commits a breach of any of the terms and conditions of the bid.
- ii. The bidder goes into liquidation, voluntarily or otherwise.  
If the selected bidder fails to complete the assignment as per the timelines prescribed in the RFP and the extension if any allowed, it will be a breach of contract. NIA reserves its right to cancel the order in the event of delay and forfeit the bid security as liquidated damages for the delay.
- iii. In case the selected bidder fails to deliver the quantity as stipulated in the delivery schedule, NIA reserves the right to procure the same or similar product from alternate sources at the risk, cost, and responsibility of the selected bidder, after 2 weeks of cure period.
- iv. NIA reserves the right to recover any dues payable by the selected Bidder from any amount outstanding to the credit of the selected bidder, including the pending bills and/or invoking the bank guarantee under this contract.

#### **8.1.2 Consequences of Termination**

- i. In the event of termination of the Contract due to any cause whatsoever, whether consequent to the stipulated term of the Contract or otherwise, NIA shall be entitled to impose any such obligations and conditions and issue any clarifications as may be necessary to ensure an efficient transition and effective business continuity of the Service(s) which the Vendor shall be obliged to comply with and take all available steps to minimize loss resulting from that termination/breach, and further allow the next successor Vendor to take over the obligations of the erstwhile Vendor in relation to the execution/continued execution of the scope of the Contract.
- ii. Nothing herein shall restrict the right of NIA to invoke Performance Bank Guarantee and other guarantees, securities furnished, enforce the Deed of Indemnity, and pursue such other rights and/or remedies that may be available to NIA under law or otherwise.
- iii. The termination hereof shall not affect any accrued right or liability of either Party nor affect the operation of the provisions of the Contract that are expressly or by implication intended to come into or continue in force on or after such termination.

### **8.2 Extension in Delivery Period and Liquidated Damages (LD)**

- i. Except as provided under clause “Force Majeure”, if the selected bidder fails to deliver any or all of the Goods or perform the Related Services within the period specified in the Contract, NIA may without prejudice to all its other remedies under the Contract, deduct from the Contract Price, as liquidated damages, a sum equivalent to the percentage specified in sub clause (iv) below for each week or part thereof of delay until actual delivery or performance, up to a maximum deduction of the percentage specified in sub clause (iv). Once the maximum timeline is reached, the Purchaser may terminate the Contract pursuant to clause “Termination”.
- ii. The time specified for delivery in the tender form shall be deemed to be the **essence of the contract** and the selected bidder shall arrange goods supply and related services within the specified period.
- iii. Delivery and completion period may be extended with or without liquidated damages if the delay in the supply of goods or service is on account of hindrances beyond the control of the

selected bidder to be determined by NIA.

- a. The supplier / selected bidder(s) shall request in writing to NIA giving reasons for extending the delivery period of service, if he finds himself unable to complete the supply of goods or service within the stipulated delivery period or is unable to maintain prorate progress in the supply of goods or service delivery. This request shall be submitted as soon as a hindrance in delivery of goods and service occurs or within **15 days** from such occurrence but before expiry of stipulated period of completion of delivery of goods and service after which such request shall not be entertained.
- b. NIA shall examine the justification of causes of hindrance in the delivery of goods and service and the period of delay occurred due to that and recommend the competent authority on the period of extension which should be granted with or without liquidated damages.
- c. If the competent authority agrees to extend the delivery period / schedule, an amendment to the contract with suitable denial clauses and with or without liquidated damages shall be issued. The amendment letter shall mention that no extra price or additional cost for any reason, whatsoever beyond the contracted cost shall be paid for the delayed supply of goods and service.
- d. It shall be at the discretion of the competent authority to accept or not to accept the supply of goods and/ or services rendered by the contractor after the expiry of the stipulated delivery period, if no formal extension in delivery period has been applied and granted. The competent authority shall have right to cancel the contract with respect to undelivered goods and / or service.
- e. In case of extension in the delivery and / or completion period is granted with full liquidated damages, the recovery shall be made on the basis of following percentages of value of goods which the selected bidder has failed to supply or complete:

No.	Condition
1	For delay in delivery of materials beyond the delivery schedule mentioned in the work order, <b>LD @ 0.5%</b> per week or part thereof for the pending materials order value up to maximum <b>5%</b> will be deducted.

- f. The maximum amount of liquidated damages shall be 5% of the total order value.
- g. NIA reserves its right to recover these amounts by any mode such as adjusting from any payments to be made by NIA to the bidder.

### 8.3 Service Level Agreement and Penalties

- i. SLA defines the terms of the successful bidder's responsibility in ensuring the performance of the hardware & all other accessories supplied as per the **Scope of Work** as specified in the RFP document based on the agreed Performance Indicators.
- ii. The Bidder shall provide comprehensive, end-to-end service including supply, warranty and replacement of the defective Hardware & peripherals in case of physical damage until delivered at the NIA Campus, Balewadi. No reason shall be entertained (unless those mentioned in Force Majeure) in case of un-availability of any service given in the Scope of Work in this RFP and the appropriate penalty shall be levied.
- iii. The selected bidder and NIA shall regularly review the performance of the services being provided by the selected bidder and the effectiveness of this SLA.
- iv. The following measurements and targets shall be used to track and report performance on a regular basis. The targets shown in the following tables are applicable for the entire

duration of the Contract /Project, failing which the selected bidder(s) is liable to be penalized:

Sl. No.	Type of Incident	Target Resolution Time	Penalty
		T+7 days	No penalty
		> T+ 7 days	0.5% of cost of the Hardware & Peripherals will be deducted per week up to maximum 5% of
1.	Any defect in Hardware & peripherals or any of its part		Faulty AV Hardware / Peripheral cost.
			If the selected bidder
		> T + 60 Days	fails to rectify a defect within 90 days, NIA may proceed to take such remedial
			action as may be necessary (including Invocation of PBG), in addition to other recourses available in terms and conditions of the contract and bidding document

**Note: -**

1. *Upper limit of the penalties due to default in SLA Warranty is 5% of the entire PO value.*
2. *T is the time when user reports the defect with the AV Hardware and peripherals by complain log in through web/ help desk. The bidder shall generate a Ticket on receipt of complaint and also has to keep proper record of 'Complaint Date' & 'Issue Resolution Date.'*

#### **8.4 Dispute Resolution Mechanism**

The Bidder and NIA shall endeavour their best to amicably settle all disputes arising out of or in connection with the Contract in the following manner:

- i. The Party raising a dispute shall address to the other Party a notice requesting an amicable settlement of the dispute within **seven (7) days** of receipt of the notice.
- ii. The matter will be referred for negotiation between NIA and the Authorized Official of the Bidder. The matter shall then be resolved between them, and the agreed course of action documented within a further period of 15 days.
- iii. In case, it is not resolved, it will be referred to The Director, NIA and his decision would be final

and binding for both the parties.

- iv. In case any dispute between the Parties, does not settle by negotiation in the manner as mentioned above, the same may be resolved exclusively by arbitration and such dispute may be submitted by either party for arbitration within 20 days of the failure of negotiations. Arbitration shall be held in Pune and conducted in accordance with the provisions of Arbitration and Conciliation Act, 1996 or any statutory modification or re-enactment thereof. Each Party to the dispute shall appoint one arbitrator each and the two arbitrators shall jointly appoint the third or the presiding arbitrator.
- v. The “Arbitration Notice” should accurately set out the disputes between the parties, the intention of the aggrieved party to refer such disputes to arbitration as provided herein, the name of the person it seeks to appoint as an arbitrator with a request to the other party to appoint its arbitrator within 45 days from receipt of the notice. All notices by one party to the other in connection with the arbitration shall be in writing and be made as provided in this tender document.
- vi. Each Party shall bear the cost of preparing and presenting its case, and the cost of arbitration, including fees and expenses of the arbitrators, shall be shared equally by the Parties unless the award otherwise provides. The Bidder shall not be entitled to suspend the Service/s or the completion of the job, pending resolution of any dispute between the Parties and shall continue to render the Service/s in accordance with the provisions of the Contract/Agreement notwithstanding the existence of any dispute between the Parties or the subsistence of any arbitration or other proceedings.

#### **8.5 Notices**

Notice or other communications given or required to be given under the contract shall be in writing and shall be faxed/e-mailed/hand-delivery with acknowledgement thereof or transmitted by pre-paid registered post or courier.

#### **8.6 Force Majeure**

Force Majeure is herein defined as any cause, which is beyond the control of the selected bidder or NIA, as the case may be, which they could not foresee or with a reasonable amount of diligence could not have foreseen and which substantially affect the performance of the contract, such as:

- i. Natural phenomenon, including but not limited to floods, droughts, earthquakes, and epidemics
- ii. Acts of any government, including but not limited to war, declared or undeclared priorities, quarantines and embargos
- iii. Terrorist attack, public unrest in work area provided either party shall within 10 days from occurrence of such a cause, notifies the other in writing of such causes. The bidder or NIA shall not be liable for delay in performing his/her obligations resulting from any force majeure cause as referred to and/or defined above. Any delay beyond 30 days shall lead to termination of contract by parties and all obligations expressed quantitatively shall be calculated as on date of termination. Notwithstanding this, provisions relating to indemnity, confidentiality survive termination of the contract.

#### **8.7 Failure to agree with Terms and Conditions of the RFP**

Failure of the successful bidder to agree with the Terms & Conditions of the RFP shall constitute sufficient grounds for the annulment of the award, in which event NIA shall invoke the PBG of the selected bidder and may award the contract to the next best value bidder or call for new proposals from the interested bidders.

\*\*\*\*\*

## **9. Details on Scope of Work**

### **9.1 Scope of Work**

All products should be offered in current production as of the date of the award. For purpose of this contract “current production” shall mean that the equipment model is being manufactured as new equipment for the Indian market. Refurbished equipment is not acceptable.

#### **9.1.1 Supply and Delivery of Hardware & peripherals**

The selected bidder is expected to carry out all activities covering Supply including delivery, installation of software and documentation, Testing, Quality Inspection in coordination with NIA Pune.

- i. Supply of all the required quantities of Hardware and peripherals having the specifications. (As mentioned in the Specifications provided in Form 4 titled “Technical Specifications”) at the NIA and in quantities as specified by the purchaser
- ii. Conduct 100% Quality inspection and testing and ensure that each and every AV/IT Hardware and other peripherals complies to the specifications given in **Form 2** and ensure that there should not be any physical damage(s) and shall contain all the required every AV/IT Hardware and other peripherals before declaring them as “Ready for delivery”.
- iii. The bidder will provide the soft copy and hard copy of both listing every Hardware and other peripherals serial nos. to NIA for better monitoring purposes.
- iv. The Delivery Challan, Inspection Report & Acceptance Note will constitute the Final Acceptance of every IT Hardware and other peripherals supplied.

#### **9.1.2 Bill of Materials [BoM]**

The Item details, brands, specifications, quantity etc of each item is as per Form 3, i.e. Compliance Sheet for Technical Proposal

#### **9.1.3 Comprehensive OEM Warranty and support services**

The Successful bidder shall:

- i. Provide comprehensive OEM Warranty and support services through its designated Support Service Centres / Service Engineers.
- ii. Warranty to start from the date of acceptance of installation at Site.
- iii. Be responsible for ensuring adequate and timely availability of spare parts needed for repairing the supplied goods at the Service Support Centres / Service Engineers during the warranty period.
- iv. The Successful bidder to provide Single Point of Contact Details (SPOC) for warranty and Support at NIA at the time of final delivery and installation of material.

### **9.2 Sub-contracting**

- i. The bidder shall not assign or sub-let its contract or any part thereof to any other agency.
- ii. Subcontracting shall in no event relieve the Supplier/ Selected bidder(s) from any of its obligations, duties, responsibilities, or liability under the Contract



### 9.3 Roles and Responsibilities

#### National Insurance Academy (NIA):

NIA may

- i. Conduct Pre-Delivery/Post-delivery Inspection.  
In-case of Pre-Delivery / Factory Sight Inspection, the bidder has to bear the entire cost including all arrangements except the travel cost which will be borne by NIA.
- ii. Authorize the concerned person of NIA to sign on the Delivery Challan.

### 9.4 Delivery/ Installation Schedule:

The Bidder shall ensure that all the required quantities of the ordered AV Hardware and peripherals are supplied, delivered, and installed to the desired location(s) as per the schedule given below:

S.N.	Identification Lot	Quantity to be Delivered (in % age)	Delivery Schedule in Weeks
1	Complete Lot	100% of total BoM	At NIA within 6 weeks, from the Date of receipt of Purchase Order or make it available at Vendor's warehouse at Pune which will be verified by NIA Officials (if required).
			At desired location of NIA, within 1 weeks, after verification done by NIA.

#### Installation

**Installation of Materials at Sites / given locations to be completed preferably within Three Weeks of delivery of material at that NIA. However, it may please be noted that the Two Classrooms will only be available for installation of equipment on weekends i.e. Saturdays / Sundays and Holidays only. As the classes are going to be conducted regularly on weekdays, there should not be any disruption to the functioning of existing classes.**

The arrival of goods must be informed to NIA in advance (before 3 days minimum), so that NIA will physically verify the same in the local go-down of the selected bidder or at NIA store. The time taken for AV Hardware and peripherals inspection & verification by NIA shall be excluded from the delivery period mentioned in the Delivery Schedule of the RFP.

### 10. Right to alter Quantities

NIA reserves the right to give repeat order to the L1 bidder in Respective Package for maximum up to 25% of ordered quantity, if required, within the tender validity period of from the last date of submission of bid under same terms and conditions with same Specifications and Rate. Any decision of NIA in this regard shall be final, conclusive, and binding on the bidder. If NIA does not purchase any of the tendered articles or purchases less than the quantity indicated in the bidding document, the bidder(s) shall not be entitled to claim any compensation.

NIA reserves the right to drop any item after technical evaluation and complete the bidding, without considering that/those item(s).

## **11. Confidential Information**

NIA and Selected bidder shall keep confidential and not, without the written consent of the other party hereto, divulge to any third party any documents, data, or other information furnished directly or indirectly by the other party hereto in connection with the Contract, whether such information has been furnished prior to, during or following completion or termination of the Contract.

## **12. Specifications and Standards**

- All articles to be supplied shall strictly conform to the specifications, trademark laid down in the tender form and wherever articles have been required according to ISI/ ISO/ other applicable specifications / certifications / standards, those articles should conform strictly to those specifications / certifications / standards. The supply shall be of best quality and description. The decision of the competent authority / purchase committee whether the articles supplied conform to the specifications shall be final and binding on the selected bidder.
- **Technical Specifications:**
  - i. The Selected bidder shall ensure that the goods and related services comply with the technical specifications and other provisions laid down in the RFP & the work order.
  - ii. The goods and related services supplied under this Contract shall conform to the standards mentioned in bidding document and, when no applicable standard mentioned, the standard shall be equivalent or superior to the official standards whose application is appropriate to the country of origin of the Goods.

## **13. Packing and Documents**

- a. The Selected bidder shall provide such packing of the Goods as is required to prevent their damage or deterioration during transit to their final destination. During transit, the packing shall be sufficient to withstand, without limitation, rough handling and exposure to extreme temperatures, salt and precipitation, and open storage. Packing case size and weights shall take into consideration, where appropriate, the remoteness of the final destination of the Goods and the absence of heavy handling facilities at all points in transit.
- b. The Bidder shall be responsible for any defect in packing and any material found damaged / defective at the delivery points and those are to be replaced by the selected bidder within 2 weeks without any financial obligations to NIA.

## **14. Transit Insurance**

- a. The Hardware and peripherals to be supplied under the Contract shall be fully insured against any loss during transit from Bidder site to NIA site.  
The insurance charges will be borne by the supplier and NIA will not pay such charges.
- b. The bidder has to submit the certificate of insurance (from third party insurance agency/ self) covering all the risks mentioned above.

## **15. Inspection**

- i. NIA or its duly authorized representative shall at all reasonable times have access to the Bidders' premises and shall have the power at all reasonable times to inspect and examine the materials

and workmanship of the goods/ equipment/ machineries during manufacturing process or afterwards as may be decided.

- ii. NIA may conduct inspection for which the cost shall be borne by NIA. NIA shall undertake the inspection of the AV Hardware and peripherals in accordance with the standard procedures being followed by NIA in Quality Inspection.
- iii. The inspection team shall prepare a Report specifying satisfactory operational condition of the inspected AV Hardware, gaps identified, and necessary corrective measurements required by the Bidder.
- iv. NIA may engage any Third-Party Agency (TPA), who shall be responsible to perform the inspection of the Hardware & peripherals in accordance with Industry Standards. NIA shall bear the inspection charges of TPA.
- v. Bidder need not provide any 3rd party software required by NIA during verification. But the bidder has to demonstrate availability / usability of all software mentioned in the Technical Specification.

## **16. Rejection**

Articles not approved during inspection or testing shall be rejected and will have to be replaced by the selected bidder(s) at his own cost within 3 business days or the time fixed by Competent Authority.

## **17. Authenticity of Equipment(s)**

- i. The selected bidder shall certify that the supplied goods are brand new, genuine / authentic, not refurbished, confirm to the description and quality as specified in this bidding document and are free from defects in material, workmanship, and service.
- ii. If during the contract period, the said goods be discovered counterfeit/ unauthentic or not to confirm to the description and quality aforesaid or have determined (and the decision of NIA in that behalf will be final and conclusive), notwithstanding the fact that the purchaser may have inspected and/ or approved the said goods, the purchaser will be entitled to reject the said goods or such portion thereof as may be discovered not to confirm to the said description and quality, on such rejection the goods will be at the selected bidder's risk and all the provisions relating to rejection of goods etc., shall apply.
- iii. Goods accepted by the purchaser in terms of the contract shall in no way dilute purchaser's right to reject the same later, if found deficient in terms of this clause of the contract.

## **18. Limitation of Liability**

Except in cases of gross negligence or willful misconduct:-

- a. neither party shall be liable to the other party for any indirect or consequential loss or damage, loss of use, loss of production, or loss of profits or interest costs, provided that this exclusion shall not apply to any obligation of the supplier / selected bidder to pay liquidated damages to the Purchaser; and
- b. the aggregate liability of the selected bidder to the Purchaser, whether under the Contract, in tort, or otherwise, shall not exceed the amount specified in the Contract, provided that this limitation shall not apply to the cost of repairing or replacing defective equipment, or to any obligation of the supplier / selected bidder(s) to indemnify the Purchaser with respect to patent infringement.

## **19. Change in Laws & Regulations**

1. Unless otherwise specified in the Contract, if after the date of the Invitation for Bids, any law, regulation, ordinance, order or bylaw having the force of law is enacted, promulgated, abrogated, or changed in Maharashtra / India, where the Site is located (which shall be deemed to include any change in interpretation or application by the competent authorities) that subsequently affects the Delivery Date and / or the Contract Price, then such Delivery Date and /or Contract Price shall be correspondingly increased or decreased, to the extent that the Supplier has thereby been affected in the performance of any of its obligations under the Contract.
2. Notwithstanding the foregoing, such additional or reduced cost shall not be separately paid or credited, if the same has already been accounted for in the price adjustment provisions where applicable.

## **20. Payment Terms and Procedure**

### **20.1.Paying Authority**

The payments as per the Payment Schedule covered herein above shall be paid by NIA. However, Payment of the Bills would be payable, on receipt of advice / confirmation for satisfactory delivery / installation / re-installation, and inspection / service report from the authorized official of National Insurance Academy.

### **20.2.Payment Schedules**

- a. No advance payment will be made.
- b. Payment of the 50% of the order value shall be made by NIA within 15 days of 100% of material delivery at the site in good condition and verification by NIA.
- c. Another 40% payment shall be made within 15 days after installation, testing & commissioning of products at the designated location and its acceptance by NIA. The bidder should also hand over the OEM warranty cards of equipment, Installation reports and User Manuals to NIA officials before claiming for the second payment.
- d. Remaining 10% will be paid against submission of additional bank guarantee of 5% of total order value for the period of warranty of 3 years. [ Up to the date of Initial PBG Submitted by Vendor]
- e. All payments are subject to statutory deductions, wherever applicable
- f. The selected bidder's request for payment shall be made to NIA in writing, accompanied by invoices describing, as appropriate, the goods delivered and related services performed, and by the required documents submitted pursuant to general conditions of the contract and upon fulfillment of all the obligations stipulated in the Contract.
- g. Due Payments shall be made promptly by NIA, generally within fifteen (15) days after submission of an invoice and other supporting documents in order.
- h. The currency or currencies in which payments shall be made to the supplier / selected bidder(s) under this Contract shall be Indian Rupees (INR) only.
- i. All remittance charges will be borne by the selected bidder.
- j. In case of disputed items, disputed amount shall be withheld and will be paid only after settlement of the dispute.
- k. Any penalties/ liquidated damages, as applicable, for delay and non-performance, as mentioned in this bidding document, will be deducted from the payments for the respective milestones. Taxes, as applicable, will be deducted at source, from due payments, as per the prevalent rules and regulations.

## **21. Appendix I: Pre-Qualification – cum – Technical Bid Template**

### **21.1.General**

The bidders are expected to respond to the RFP using the forms given in this section and all documents supporting Pre-Qualification–cum-Technical Evaluation Criteria. Pre- Qualification Bid – cum – Technical Proposal shall comprise of following forms:

### **22. Compliance Sheet for Prequalification cum Technical Evaluation:**

<b>Sl. No.</b>	<b>Basic Requirement</b>	<b>Documents Required</b>	<b>Complied (Yes / No)</b>	<b>Reference &amp; Page Number</b>
1.	Document / Tender Fee	Receipt for Rs.1000.00 + GST		
2.	Bid Security / EMD	Receipt for Rs.1,75,000.00 + GST		
3.	Power of Attorney / Authorization Letter	Copy of Power of Attorney/ Authorization in the name of the Authorized signatory		
4.	Particulars of the Bidders	As per <b>Form 1</b>		
5.	Average Sales Turnover in Hardware Sales & Maintenance services in three financial years	Extracts from the audited Balance sheet and Profit & Loss; OR Certificate from the statutory auditor		
6.	The net worth of the bidder in the last three financial years (showing for Average Sales Turnover in Hardware Sales & Maintenance services), should be positive.	CA Certificate with CA's Registration Number / Seal indicating net worth of the firm		
7.	Technical Capability	Work Order + Completion Certificates from the clients		
8.	Legal Entity	Copy of Certificate of Incorporation, GST registration, PAN, IT return		
9.	Compliance Sheet for Technical Proposal.	As per <b>Form - 2</b>		
10.	Local Service Centres	A Self Certified Letter / Undertaking by an authorized signatory		
10.	Blacklisting & Performance	A self-certified letter		
11.	Undertaking on Authenticity of AV Hardware & peripherals (To be filled by the bidder (On ₹.100/- Non-judicial stamp paper)	As per <b>Form - 5</b>		

(The Pre-Qualification – cum – Technical proposal should comprise of the following basic requirements. The documents mentioned in this compliance sheet along with this form, needs to be a part of the Pre-Qualification proposal and required to be uploaded)

**Form 1: Particulars of the Bidders**

<b>INDIVIDUAL / FIRM / COMPANY PROFILE</b>		
<b>Sr. No.</b>	<b>Required Information (QUERY)</b>	<b>ANSWER</b>
1	Name and registered address of the Individual/firm/company.	
2	Name, designation, and telephone nos. of the contact person / persons. Mobile Nos. Fax No. E-mail id	
3	Month and Year of commencement of service business in present name.	
4	<b>(Photocopies of following documents to be Uploaded)</b>	
	1. Registration number of the firm. (As per Shop and Establishment act.)	
	2. PAN No. and TIN No.	
	3. Goods and Service Tax No	
5	Name and complete postal address of bankers.	
	Name of Bank	
	Branch	
	Account No	
	Account Type	
	IFSC Code	
6	Additional Information if any.	

**Form 2: Compliance Sheet for Technical Proposal**

(Note: All the specifications below are minimum specifications and higher specifications shall be used wherever necessary / required. Deviation on higher side shall only be considered and no extra weightage shall be awarded for such deviations. The bidder needs to fill up and upload the technical compliance sheet as per Form 2.)

**TECHNICAL SPECIFICATIONS**

S. N.	SPECIFICATIONS	MINIMUM REQUIREMENT	YOUR COMPLIANCE TO MINIMUM REQUIREMENT
<b>NOTE: "Compliance of the bidder with only a 'Yes' or 'No' answer will be liable for tender rejection unless actual information is filled in the Compliance Column."</b>			
<b>I. 98" ULTRA HD 4K LED DISPLAY</b>		<b>QTY- 2 Nos</b>	
1	<b>Make</b>	ViewSonic / LG / BenQ	
2	<b>Model</b>	<b>Ref Model: [ViewSonic-IFP9850-4 / LG-98TE3PJ-DK] or equivalent of above other brands.</b>	
3	Native Resolution	UHD 3840x2160(Pixels)	
4	Colors	1.07B colors (10bit)	
5	Brightness	350 nits (typ.)	
6	Contrast Ratio	1200:1 Typ., 4000:1, Max. (DCR enable)	
7	Response Time	8ms	
8	Viewing Angles	H = 178, V = 178 typ.	
9	Backlight Life	50,000 Hours (Min.)	
10	Surface Treatment	Hardness: 9H pencil, Anti-Fingerprint coating, Anti-Glare coating	
11	Touch glass thickness	<i>(Please specify)</i>	
12	Haze	28%	
13	Bezel (L/R/T/B)	26/26/26/44 mm	
14	Orientation	Landscape	
15	Processor	ARM Cortex A73*4 (1.8GHz)	
16	RAM	4G DDR4	
17	Storage	32GB	
18	Touch Type/ Tech	IR Recognition	
19	Touch Resolution	32767 x 32767	
20	Touch Point	20	
21	Point of writing	10	
22	Response Time	≤10ms	
23	Scan rate	≥100HZ	

24	Accuracy size	90% area +/- 1mm	
25	Pen tips size	2.5mm/8mm	
26	HDMI-IN	2.0 x3 (3840x2160 @60Hz)	
27	RGB / VGA	x1	
28	Audio	x1 (PC audio in)	
29	RS232	x1	
30	OPS	x1 PC Slot (proprietary)	
31	HDMI-OUT	x1	
32	Audio	x1 (Earphone out)	
33	SPDIF	1(optical)	
34	RS232	x1	
35	RJ45	x1 (10/100M/1000M for both VPC and embedded player), 100M for type - C	
36	Type A	USB 3.0 x 3(Side), front x2	
37	Type B	x2, for touch	
38	Type C	01	
39	SPEAKERS	16Wx2	
40	USB SUPPORTED FILE FORMAT	Picture - JPEG, BMP, PNG, GIF Audio - Code protocol: MPEG1, MPEG2, MP3, AAC, Vorbis, LPCM, LBR (cook), OPUS, FLAC, APE, AMR-NB, AMR-WB Video-Code protocol: VP9, HEVC /H.265, MPEG1/2, MPEG4, H.263, H.264, VC1, MJPEG, VP8, RV30/RV40, AVS, AVS2, AV1	
41	All-in-one USB port (combine Windows /Android USB port; no need to distinguish them anymore)	All USB3.0 support smart port	
42	Simple LAN sharing between IFP and slot-in device	10/100/1000 for Android and slot-in PC, 100M for type-c	
43	Light sensor	Yes	
44	Temperature (° C)	0°C to 40°C	
45	Humidity	10% ~ 90% RH non-condensing	
46	REGULATIONS	FCC, cTUVus, EPEAT, ES8, LBL, CE, CB, RCM	
47	Energy Star version	ES8.0	
48	PACKAGE CONTENTS	<b>(Please Specify – all items)</b>	
49	<b>On Site Warranty</b>	<b>3 Years from the date of acceptance</b>	



<b>II. WALL MOUNT KIT FOR 98" LED DISPLAY</b>			<b>QTY- 2 Nos</b>
1	Make	Lumi / Chief / Btech	
2	Model	<b>LP37-810T or equivalent of above other brands.</b>	
3	Material	M.S.	
4	Finish	Powder Coated	
5	On Site Warranty	<b>3 Years from the date of acceptance</b>	
<b>III. 55" ULTRA HD DISPLAY</b>			<b>QTY- 2 Nos</b>
1	Make	Samsung / LG / Panasonic / ViewSonic	
2	Model	<b>[Ref Model: Samsung QB55C] or equivalent of above other brands.</b>	
3	Native Resolution	UHD 3840x2160 (Pixels)	
4	Brightness	350 nits (typ.)	
5	Contrast Ratio	1100:1	
6	Viewing Angle (H/V)	178 <sup>0</sup> / 178 <sup>0</sup>	
7	Response Time	8 ms	
8	On Site Warranty	<b>3 Years from the date of acceptance</b>	
<b>IV. WALL MOUNT KIT FOR 55" DISPLAY</b>			<b>QTY- 2 Nos</b>
1	Make	Lumi / Chief / Btech	
2	Model	<b>[Ref Model: Lumi PLB-M06H] or equivalent of above other brands.</b>	
3	Swivel Mount	YES / NO	
4	On Site Warranty	<b>3 Years from the date of acceptance</b>	
<b>V. CAMERA FOR PRESENTER</b>			<b>QTY- 2 Nos</b>
1	Make	Lumens / Sony / Vaddio	
2	Model	<b>[Ref Model: Lumens VC-TR40] or equivalent of above other brands.</b>	
3	AI based Full HD 1080p @ 60fps Presenter PTZ Tracking Camera with Dual Camera -one PTZ Camera for Presenter Tracking and second fixed lens Panoramic Camera. PTZ Presenter Camera should support min 20X Optical Zoom and 12x Digital Zoom with Panning range of +170 deg to - 170 deg and Tilt Range of -30 to +90 Degrees, Field of View for PTZ Camera should be min 58 Degree and for Panoramic Camera min. 100 Degree, camera should support simultaneous outputs through HDMI, 3G-SDI, USB 3.0 and IP with 1x Audio In and can be controlled via RS232 and IP. Should support multiple video streams. Tracking Camera should support Everywhere Tracking, Partition Tracking, Auto Framing & Gesture Control. Should support PoE and Virtual USB Driver. Quoted model should be BIS, CE, FCC, Clickshare & RoHS Certified with Test		

	Lab Reports. With Camera Mount.		
4	<b>On Site Warranty</b>	<b>3 Years from the date of acceptance</b>	
<b>VI. CAMERA FOR STUDENTS</b>			<b>QTY- 4 Nos</b>
1	<b>Make</b>	Lumens / Sony / Vaddio	
2	<b>Model</b>	<b>[Ref Model: Lumens VC-R31] or equivalent of above other brands.</b>	
3	Full HD PTZ Camera supporting 1080p at 60 Frames per Second, minimum 12X Optical Zoom with FoV of minimum 70 degree and minimum 255 presets. Camera should support simultaneous outputs through HDMI, USB 3.0 & IP with Audio In and controllable via RS232/422 and IP. Panning angle -170° ~ +170°, Tilting angle -30° ~ +90. Camera should support SRT, PoE & should be compatible with Virtual USB Driver. Quoted model should be BIS, Clickshare, CE, FCC & RoHS Certified with Test Lab Reports. with Camera Mount.		
4	<b>On Site Warranty</b>	<b>3 Years from the date of acceptance</b>	
<b>VII. CAMERA MIXER</b>			<b>QTY- 2 Nos</b>
1	<b>Make</b>	Lumens / MediaPoint / VBrick / Sony	
2	<b>Model</b>	<b>[Ref Model: Lumens Media Processor-VS-LC200] or equivalent of above other brands.</b>	
3	Recording, Streaming & Webcasting Hardware simultaneously Built-in 4x HDMI & IP Inputs with 4x Line Inputs, 2x HDMI Outputs. The system should be capable of recording up to any four inputs simultaneously in a single frame and as well as individual sources simultaneously. Should have minimum 1TB inbuilt storage and can be connected to local NAS storage. The system should be able to support a minimum of 3 unicast streams. The recorded files should have the option of time and date stamp. Quoted model should be CE, FCC & RoHS Certified.		
4	<b>On Site Warranty</b>	<b>3 Years from the date of acceptance</b>	
<b>VIII. CAPTURE CARD</b>			<b>QTY- 2 Nos</b>
1	<b>Make</b>	Inogeni / Lumens / Panasonic	
2	<b>Model</b>	<b>Ref Model: Inogeni 4KXUSB3] or equivalent of above other brands.</b>	
3	4K Ultra HDMI to USB 3.0 Convertor	YES / NO	
4	<b>On Site Warranty</b>	<b>3 Years from the date of acceptance</b>	

<b>IX. CEILING MICROPHONE</b>			<b>QTY- 2 Nos</b>
1	Make	Sony OR Sennheiser	
2	Model	<b>[Ref Model: Sony MAS-A100] or [Sennheiser TCC M-S Team Connect Ceiling Medium Surface Mount]</b>	
3	Audio technologies	Beamforming	
		Feedback reducer	
		Automatic gain control	
		Noise reduction	
		Noise gate	
		Automatic calibration with test signal	
		Equaliser	
		API for external control system	
4	Noise & Feedback Reduction	Maximum noise reduction: 24dB	
		Maximum feedback reduction: 32dB	
5	Speech Reinforcement	Yes	
6	Frequency response	100-10,000 Hz	
7	Sensitivity	0dBFS/Pa at 1kHz	
8	Maximum SPL	94dBSPL	
9	Signal to noise ratio	75dB	
10	Latency	Under 24ms	
11	Self-noise	19dBSPL	
12	Dynamic Range	75 dB	
13	No of mics/unit	minimum 8	
14	Auto Calibration	Yes	
15	Dante digital output	Channel count: 2 channels (Main, Rec) with Dante Sampling rate: 48 kHz Bit depth: 24 Audio interface: Dante, AES67	
16	Mic Range	Main Channel: 3 Mtr Radius Recording Channel: 7 Mtr Radius	
17	Mic Gain	-60dB ~ +12dB	
18	Capture range	Narrow / standard / wide	
19	Noise reduction	Low/ middle / high	
20	Feedback reduction	Low/ middle / high	

21	Equaliser	Fixed 5-band, ±12dB (1dB Step)	
22	Audio Connector type	RJ45	
23	Power requirements	Power over Ethernet (PoE)	
24	Power consumption	13W	
25	Mounting	Ceiling	
26	<b>On Site Warranty</b>	<b>3 Years from the date of acceptance</b>	

<b>X HEADWORN WIRELESS MICROPHONE</b>		<b>QTY- 2 Nos</b>	
---------------------------------------	--	-------------------	--

1	Make	Shure / Sennheiser / AKG	
2	Model	<b>[Ref Model: Sennheiser - HSP4 EW3] or equivalent of above other brands.</b>	
3	Excellent feedback rejection	YES / NO	
4	Microphone includes a detachable cap as integral wind / pop shield.	YES / NO	
5	Individually adjustable to all head sizes	YES / NO	
6	Neckband design keeps the microphone clear from shirt-collar or clothing	YES / NO	
7	Twist-proof microphone boom (Ø 2.0 mm), can be attached to the left or right side.	YES / NO	
8	Microphone boom is adjustable in length and angle.	YES / NO	
9	Flexible gooseneck section.	YES / NO	
10	Connection cable can easily be interchanged.	YES / NO	
11	All metal parts coated in a physical vapour deposition process.	YES / NO	
12	Should support LAVALIER mic receiver	YES / NO	
13	<b>On Site Warranty</b>	<b>3 Years from the date of acceptance</b>	

<b>XI HANDHELD WIRELESS MICROPHONE</b>		<b>QTY- 2 Nos</b>	
--	--	-------------------	--

1	Make	Shure / Sennheiser / AKG	
2	Model	<b>[Ref Model: Sennheiser - EWD 835-S SET] or equivalent of above other brands.</b>	
3	Digital wireless handheld Microphone with UHF transmission greatly enhances range, reliability and scalability of 56 MHz Bandwidth will allow for up to 80 channels Up to 2,240 selectable frequencies with Mobile App streamlines	YES / NO	

	setup and operation and eliminates complicated menus and Automated setup creates reliable connections with minimal time and effort Preserves every detail of even the most dynamic performances with 134 dB transmitter dynamic range Lithium Ion battery pack delivers up to 12 hours of operation (up to 8 hours of operation with AA batteries) Transducer principle dynamic with Pick-up pattern cardioid, Sound pressure level 154 dB SPL, Transmit power (radiated) Audio link: 10 mW ERP (Range Y1-3: 12 mW ERP) BLE: max.10 mW EIRP		
<b>4</b>	<b>On Site Warranty</b>	<b>3 Years from the date of acceptance</b>	
<b>XII LAVALIER WIRELESS MICROPHONE</b>			<b>QTY- 8 Nos</b>
1	Make	Shure / Sennheiser / Beyerdynamic	
2	Model	<b>[Ref Model: Sennheiser EWD ME4 Set] or equivalent of above other brands.</b>	
3	Digital transmission operating in the UHF spectrum greatly enhances range, reliability and scalability	YES / NO	
4	Smart Assist App connects via Bluetooth Low Energy for a streamlined setup and operation at a distance	YES / NO	
5	Auto scan creates reliable connections with minimal time and effort	YES / NO	
6	134 dB audio input dynamic range eliminates need for sensitivity adjustments and preserves every detail	YES / NO	
7	Elimination of intermodulation enables channels to be placed in an equidistant tuning grid 600 kHz apart	YES / NO	
8	56 MHz of tuning bandwidth and equidistant spacing enables up to 80 channels	YES / NO	
9	2,240 selectable frequencies	YES / NO	

10	Lithium-Ion battery pack delivers up to 12 hours of operation (up to 8 hours of operation with 2x provided AA batteries)	YES / NO	
11	Cardioid clip-on microphone.	YES / NO	
12	<b>On Site Warranty</b>	<b>3 Years from the date of acceptance</b>	
<b>XIII 12-CHANNEL MIXING CONSOLE</b>			<b>QTY- 2 Nos</b>
1	Make	Yamaha / Sound craft / Behringer	
2	Model	<b>Ref Model: Yamaha – MG Series or equivalent of above other brands.</b>	
3	12-Channel Mixing Console	YES / NO	
4	+48V phantom power	YES / NO	
5	XLR balanced outputs	YES / NO	
6	Metal chassis	YES / NO	
7	Max. 6 Mic / 12 Line Inputs (4 mono + 4 stereo)	YES / NO	
8	<b>On Site Warranty</b>	<b>3 Years from the date of acceptance</b>	
<b>XIV DSP with AEC</b>			<b>QTY- 2 Nos</b>
1	Make	Kramer / BIAMP / Xilica	
2	Model	<b>[Ref Model: Xilica QR1 8X4 USB AEC] or equivalent of above other brands.</b>	
3	Quarter rack 1RU mainframe with eight user-configured card slots, and built-in 4x4 I/O of Dante network audio. Integrated license-activated AEC. Dual core processing 40-bit floating DSP. Powered using PoE or included external power supply. Surface mount bracket included.8ch Mic/Line input with selectable mic, line, mic gain, and phantom power per input. 32-bit analog to digital converters.4ch Line output. 32-bit digital to analog converters.	<b>YES / NO</b>	
4	<b>On Site Warranty</b>	<b>3 Years from the date of acceptance</b>	
<b>XV. ON-WALL POWERED SPEAKERS</b>			<b>QTY- 6 Pairs</b>
1	<b>Make</b>	QSC / Audac / Bose	
2	<b>Model</b>	<b>Ref Model: Audac ARES5A</b>	

		<b>or equivalent of above other brands.</b>	
3	Min 5" 2 way active speaker system/ speaker pair with Min RMS power of 2x20 Watts, Dynamic power handling of 2x40 Watt, frequency response (±3dB) 85Hz up to 20 kHz and the sensitivity (1W/1m) 88 dB or better and Max SPL of 104 dB or more. Speaker should have at least one unbalanced & balanced stereo inputs and additional wall panel input to connect mic/line level signal, should have H xV dispersion 180 x 180 or better,CE Certification or more	YES / NO	
4	<b>On Site Warranty</b>	<b>3 Years from the date of acceptance</b>	

**XVI - 4X3 MATRIX SWITCHER**

**QTY – 2 Nos**

1	<b>Make</b>	Lightware / Kramer / Extron	
2	<b>Model</b>	<b>[Ref Model: Lightware UCX-4X3-HC40] or equivalent of above other brands.</b>	
3	4x3 matrix with 02 full featured USB-C 3.1 Gen 1, 02 HDMI 2.0 and USB 3.1 ports and 03 HDMI output supporting 4K signal formats. (4K UHD @ 60Hz RGB 4:4:4, upto 18 Gbps) secure control Ethernet interface.	YES / NO	
4	USB-C input connectivity for 4K Video, Audio, Data, and Power Video, Audio	YES / NO	
5	Data and Power over a single USB -C connection) Multiple USB 3.1 Gen 1 connectivity for any type of USB devices (Camera, speaker- phone, touch monitor, USB-HID devices etc...)	YES / NO	
6	USB 3.1 Gen 1, USB 2.0, USB 1.1 compliant Separate USB 3.1 Host switching layer for multiple USB hosts and USB devices Charging via USB-C up to 100w	YES / NO	
7	Dedicated secure corporate and room utility Ethernet connectivity	YES / NO	

8	Multiple Ethernet network configurations fitting various corporate network topologies and IT security standards (e.g., 802.1x compliance) SSH, SSL, HTTPS for IT security Smart noiseless cooling system.	YES / NO	
9	Occupancy sensor connection (with 24V power supply)	YES / NO	
10	Splash screen for custom corporate and on-screen display warning messages	YES / NO	
11	USB-C charging up to 100W (total 120W), depending on the AC/DC power supply type	YES / NO	
12	CEC at the HDMI outputs	YES / NO	
13	Audio de-embedding GPIO control Device control via Ethernet (TCP/IP).	YES / NO	
14	Supports HDMI 4K signal formats UHD @60Hz	YES / NO	
15	RGB 4:4:4, up to 18 Gbps)	YES / NO	
16	Uncompressed video up to 18 Gbps data rate (600 MHz pixel clock)	YES / NO	
17	<b>On Site Warranty</b>	<b>3 Years from the date of acceptance</b>	

**XVII. HDMI TRANSMITTER**

**QTY- 6 Nos**

1	Make	Lightware / Kramer / Extron / Crestron	
2	Model	<b>[Ref Model: Lightware HDMI-TPS-TX96] or equivalent of above other brands.</b>	
3	HDMI 1.4 + RS-232 + bidirectional IR HDBaseT transmitter over CATx cable. HDCP, 3D and 4K / UHD ( 30Hz RGB 4:4:4 , 60Hz YCbCr 4:2:0) compliant. 100m 4k extension distance.	YES / NO	
4	<b>On Site Warranty</b>	<b>3 Years from the date of acceptance</b>	



<b>XVIII. HDMI RECEIVER</b>			<b>QTY- 6 Nos</b>
1	<b>Make</b>	Lightware / Kramer / Extron	
2	<b>Model</b>	[Ref Model: Lightware HDMI-TPS-RX86] or equivalent of above other brands.	
3	HDMI1.4 + RS-232 + bidirectional IR HDBaseT receiver over CATx cable. HDCP, 3D and 4K / UHD (30Hz RGB 4:4:4 , 60Hz YCbCr 4:2:0) compliant. 100m 4k extension distance.	YES / NO	
4	<b>On Site Warranty</b>	<b>3 Years from the date of acceptance</b>	

<b>XIX - 6X BUTTON PANEL TO TRIGGER EVENTS IN CONTROL CONFIGURATIONS</b>			<b>QTY- 2 Nos</b>
--	--	--	-------------------

1	<b>Make</b>	Lightware / Kramer / Extron	
2	<b>Model</b>	[Ref Model: Lightware TBP6-EU-K] or equivalent of above other brands.	
3	8-pole Phoenix connector (7x GPI- O + GND).	YES / NO	
4	Mountable to wall	YES / NO	
5	Status LED and backlight fed from pin on GPIO	YES / NO	
6	<b>On Site Warranty</b>	<b>3 Years from the date of acceptance</b>	

<b>XX – USB C CABLE - 3M</b>			<b>QTY- 2 Nos</b>
------------------------------	--	--	-------------------

1	<b>Make</b>	Lightware / Kramer / Extron	
2	<b>Model</b>	[Ref Model: Lightware CAB-USBC-T300A] or equivalent of above other brands.	
3	USB-C to USB-C	YES / NO	
4	Length	3 M	
5	USB Full-Featured Type-C for USB 3.1 Gen 1	YES / NO	
6	<b>On Site Warranty</b>	<b>3 Years from the date of acceptance</b>	

<b>XXI HDMI CABLE - 2M</b>			<b>QTY- 14 Nos</b>
----------------------------	--	--	--------------------

1	<b>Make</b>	Lightware / Kramer / Extron	
2	<b>Model</b>	Ref Model: Lightware CAB-HDMI20- PHS200F or equivalent of above other brands.	
3	2 M Premium High-Speed HDMI	YES / NO	

4	2.0b flexy cable.	YES / NO	
5	Thin and Flexible.	YES / NO	
6	Bandwidth up to 18Gbps.	YES / NO	
7	Enables transmission of High Dynamic Range (HDR10),	YES / NO	
8	Dolby Vision and Hybrid log- gamma (HLG) video.	YES / NO	
9	Up to 4096x2160@60Hz at RGB 4:4:4 video resolution.	YES / NO	
10	Supported Dolby True HD	YES / NO	
11	DTS-HD Master Audio and Dolby	YES / NO	
12	Atmos audio formats	YES / NO	
13	Robust shield design for extra EMI protection	YES / NO	
14	<b>On Site Warranty</b>	<b>3 Years from the date of acceptance</b>	

<b>XXII. HDMI CABLE 3 MTR</b>		<b>QTY- 14 Nos</b>	
-------------------------------	--	--------------------	--

1	<b>Make</b>	Lightware / Kramer / Extron	
2	<b>Model</b>	<b>Ref Model: Lightware CAB-HDMI20- PHS300P or equivalent of above other brands.</b>	
3	3 M Premium High-Speed HDMI	YES / NO	
4	2.0b cable.	YES / NO	
5	Bandwidth up to 18Gbps.	YES / NO	
6	Up to 4096x2160@60Hz at RGB 4:4:4 video resolution.	YES / NO	
7	<b>On Site Warranty</b>	<b>3 Years from the date of acceptance</b>	

<b>XXIII. CABLE CUBBY</b>		<b>QTY- 2 Nos</b>	
---------------------------	--	-------------------	--

1	<b>Make</b>	Logic / Kramer / Extron	
2	<b>Model</b>	<b>Ref Model: Logic or equivalent of above other brands.</b>	
3	<b>Cable Cubby with Passthrough</b>	YES / NO	
4	<b>On Site Warranty</b>	<b>3 Years from the date of acceptance</b>	

<b>XXIV 10M HIGH SPEED HDMI AOC CABLE</b>		<b>QTY- 4 Nos</b>	
---	--	-------------------	--

1	<b>Make</b>	Lightware / Kramer / Extron	
2	<b>Model</b>	<b>Ref Model: Lightware CAB-HDMI20-AOC1000H or equivalent of above other brands.</b>	

3	10 M HDMI2.0 Active Optical Cable with buffer chip. Bandwidth up to 18Gbps Up to 4096x2160@60Hz at RGB 4:4:4 video resolution The built-in buffer chip provides robust signal integrity and reliable connection. No external power needed	YES / NO	
4	<b>On Site Warranty</b>	<b>3 Years from the date of acceptance</b>	
<b>XXV USB A (M) TO B (M) CABLE – 3M</b>			<b>QTY- 6 Nos</b>
1	<b>Make</b>	Lightware / Kramer / Extron	
2	<b>Model</b>	<b>Ref Model: Kramer C-USB3/AB or equivalent of above other brands.</b>	
3	Length	3 M	
4	<b>On Site Warranty</b>	<b>3 Years from the date of acceptance</b>	
<b>XXVI AUDIO/SPEAKER/CAT6 S/FTP CABLES</b>			<b>QTY – 2 Lots</b>
1	<b>Make</b>	Extron, Belden, Kramer, Molex	
2	<b>On Site Warranty</b>	<b>3 Years from the date of acceptance</b>	
<b>XXVII DIGITAL PODIUM WITH INTERACTIVE DISPLAY</b>			<b>QTY – 2 Nos</b>
1	<b>Make</b>	Uni / AHA / Tecomm	
2	<b>Model</b>	<b>Ref Model: Uni – UNI 117 or equivalent of above other brands.</b>	
3	<b>Type</b>		
4	SITC of Slim Steel Frame (MS) with Slidable Wooden Top podium, Caster Wheels for podium movement, Drawer for keyboard mouse, External Passive Connectivity 2 X USB 3.0 , 1 X HDMI 2.0 LAN Cable, Power On/Off , 3Pin XLR connector, provision Gooseneck Microphone Holder only, 21.5' display finger touch inertactive display, Motorised tilting facility, 4x2 Matix	YES / NO	

	Switcher, 6 Universal rating 5 Amp Socket, Provision for front logo, Dimentions 835 (W) x 1062 (H) x 640 (D) mm approx. CPU/PC not included Approved Make: AHA/UNI/Tecom		
5	<b>On Site Warranty</b>	<b>3 Years from the date of acceptance</b>	
<b>XXVIII. USB 3.0 ACTIVE EXTENDER CABLE10 M</b>			<b>QTY – 2 Nos</b>
1	<b>Make</b>	Lightware / Crestron / Extron	
2	<b>Model</b>	<b>Ref Model: Lightware CAB-USB-AMAF-T1000A or equivalent of above other brands.</b>	
3	USB Full-Featured Active Extension Cable for USB 3.1 Gen 1. A/M to A/F, 10 M.	YES / NO	
4	<b>On Site Warranty</b>	<b>3 Years from the date of acceptance</b>	
<b>XXIX. COMPACT WIRELESS MICROPHONE SYSTEM</b>			<b>QTY – 4 Nos</b>
1	<b>Make</b>	Rode / Shure / Sennheiser	
2	<b>Model</b>	<b>Ref Model: RODE Wireless GO or equivalent of above other brands.</b>	
3	Ultra-compact wireless microphone system that is unique in its clip'n'go versatility and incredibly compact form-factor. The transmitter features an in-built omnidirectional condenser capsule and can be used as a clip-on mic or with a RØDE lavalier, sending crystal-clear, broadcast-grade audio via 2.4GHz digital transmission to the on-camera receiver.	YES / NO	
4	<b>On Site Warranty</b>	<b>3 Years from the date of acceptance</b>	
<b>XXX. MANAGED 08 PORT POE / POE+ SWITCH AS PER SITE REQUIREMENT</b>			<b>QTY – 2Nos</b>
1	<b>Make</b>	Netgear / Cisco / Extreme	
2	<b>Model</b>	[Ref Model: Netgear GSM4212P] or equivalent of above other brands	
3	8 x 1G PoE+125W, 2 x 1G and 2xSFP Managed Switch. 1G AV over IP	YES / NO	
4	<b>On Site Warranty</b>	<b>3 Years from the date of acceptance</b>	

**XXXI. EQUIPMENT RACK**

<b>1</b>	<b>Make</b>	Valrack / WQ / Netrack	
<b>2</b>	<b>Model</b>	<b>Ref Model: Valrack 17U x 600 W] or equivalent of above other brands.</b>	
<b>3</b>	Rack 17U, x 600W x 650D – 1, Front Glass Door, Rear Insert Door, Castors – 4, Fix Shelf 494mm W x 375mm D – 4, Fans – 2, Minimum 8 Sockets of 6/13A, Universal PDU x 2 Qty, Blank panel of 1U height – 4, Hardware, Gray or black Colour		
<b>4</b>	<b>On Site Warranty</b>	<b>3 Years from the date of acceptance</b>	

**OPTIONAL ITEMS SPECIFICATIONS****I. CAMERA FOR PRESENTER 12X**

Make	Sony	
Model	<b>Ref Model: SRG-A12</b>	
PTZ Camera Tracking	AI based built in presenter tracking	
Tracking Mode	Auto & Manual	
Tracking frame mode	03 modes (Full body, Waist & Close Up)	
Camera auto tracking control parameters	Pan, Tilt & Zoom	
Image Sensor	1/2.5 4K ExmorR CMOS	
Number of Effective Pixels	8.5 MP	
Horizontal Resolution	1700 TV Lines (4K) 1000 TV Lines (FHD)	
Signal System	2160/29.97p, 25p, 23.98p,1080/59.94p, 50p, 29.97p, 25p, 23.98p,1080/59.94i, 50i 720/59.94p, 50p	
Minimum Illumination (50IRE)	1.6 Lux (50IRE, F2.0 30fps)	
Gain	Auto/Manual (0 to +43 dB)	
Shutter Speed	1/1 to 1/10000 sec (50 Hz system)	
Exposure Control	Auto, Manual, Priority AE (Shutter,Iris), Exposure compensation, Bright	
White Balance	Auto, Indoor, Outdoor,	

	One-push auto, ATW, Manual	
Optical Zoom	12x	
Focusing System	Auto/Manual	
Horizontal Viewing Angle	70 degree (Wide)	
Pan/Tilt Angle	Pan: $\pm 170^\circ$ Tilt: $+90^\circ/-20^\circ$	
Pan/Tilt Speed (Max.)	Pan: $300^\circ/\text{sec}$ Tilt: $126^\circ/\text{sec}$	
Preset Position	100 (VISCA)/ 256 (CGI)	
Video Output	HDMI, 3G-SDI & IP (simultaneous)	
Audio Input	2ch (MIC/Line)	
Audio Embedded	Yes (3G-SDI, HDMI, IP)	
Streaming	3 Channel (Simultaneously)	
Protocols	IPv4, IPv6, TCP, UDP, ARP, ICMP, HTTP, HTTPS, DHCP, DNS, RTP/RTCP, RTSP, VISCA over IP, SRT	
Integrated Tally Lamp	Yes	
POE++	Yes	
Support Web UI	Yes	
Web UI Language Support	English & Hindi	
Mounting Option	Desktop & Ceiling	
	With Camera Mount.	
<b>II. CAMERA FOR PRESENTER 30X</b>		
Make	Sony	
Model	<b>Ref Model: SRG-A40</b>	
PTZ Camera Tracking	AI based built in presenter tracking	
Tracking Mode	Auto & Manual	
Tracking frame mode	03 modes (Full body, Waist & Close Up)	
Camera auto tracking control parameters	Pan, Tilt & Zoom	
Image Sensor	1/2.5 4K ExmorR CMOS	
Number of Effective Pixels	8.5 MP	
Horizontal Resolution	1700 TV Lines (4K) 1000 TV Lines (FHD)	
Signal System	2160/29.97p, 25p, 23.98p,1080/59.94p, 50p, 29.97p, 25p, 23.98p,1080/59.94i, 50i 720/59.94p, 50p	

Minimum Illumination (50IRE)	1.6 Lux (50IRE, F2.0 30fps)	
Gain	Auto/Manual (0 to +43 dB)	
Shutter Speed	1/1 to 1/10000 sec (50 Hz system)	
Exposure Control	Auto, Manual, Priority AE (Shutter,Iris), Exposure compensation, Bright	
White Balance	Auto, Indoor, Outdoor, One-push auto, ATW, Manual	
Optical Zoom	30x	
Focusing System	Auto/Manual	
Horizontal Viewing Angle	70 degree (Wide)	
Pan/Tilt Angle	Pan: $\pm 170^\circ$ Tilt: $+90^\circ/-20^\circ$	
Pan/Tilt Speed (Max.)	Pan: $300^\circ/\text{sec}$ Tilt: $126^\circ/\text{sec}$	
Preset Position	100 (VISCA)/ 256 (CGI)	
Video Output	HDMI, 3G-SDI & IP (simultaneous)	
Audio Input	2ch (MIC/Line)	
Audio Embedded	Yes (3G-SDI, HDMI, IP)	
Streaming	3 Channel (Simultaneously)	
Protocols	IPv4, IPv6, TCP, UDP, ARP, ICMP, HTTP, HTTPS, DHCP, DNS, RTP/RTCP, RTSP, VISCA over IP, SRT	
Integrated Tally Lamp	Yes	
POE++	Yes	
Support Web UI	Yes	
Web UI Language Support	English & Hindi	
Mounting Option	Desktop & Ceiling With Camera Mount.	

# Proposed Schematic Diagram:

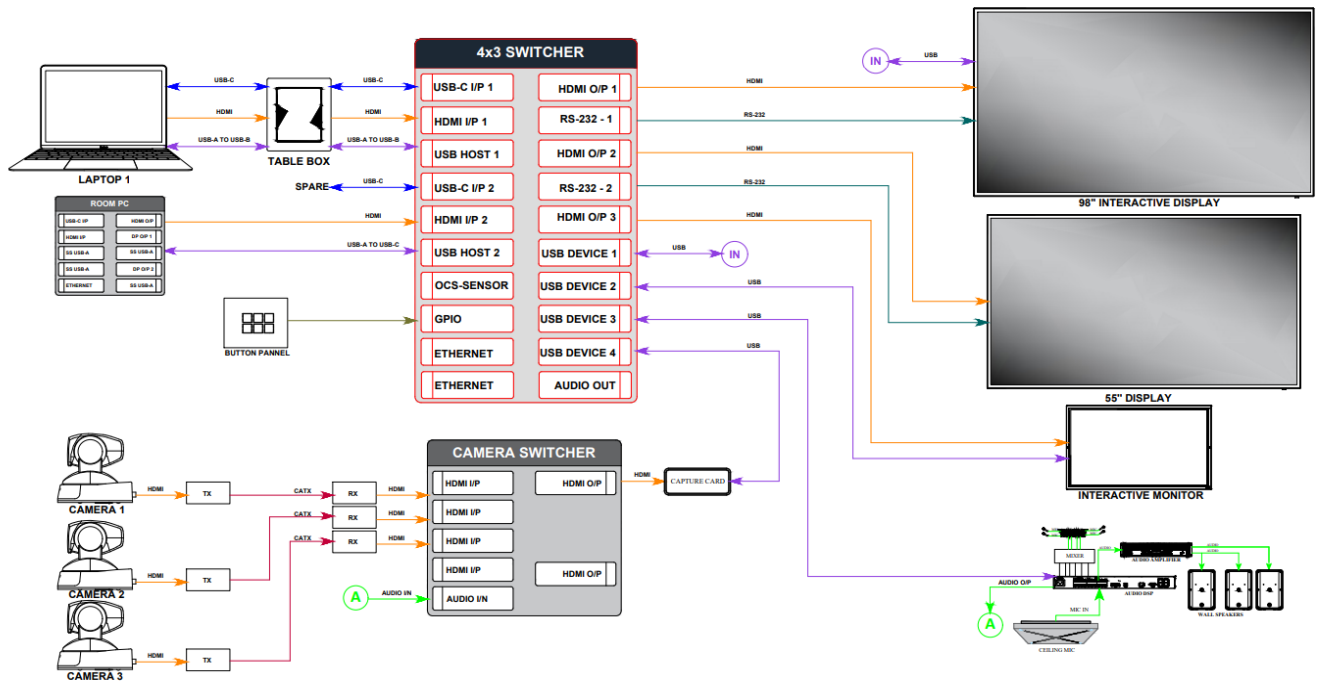



**Form 3: Letter of Proposal**

To,

The Director  
National Insurance Academy  
25, BalewadI, Baner Road,  
NIA Post Office,  
Pune - 411045

**Re:** Submission of the Technical bid for Supply and Installation of integrated solution of LED Display, Interactive Touch Monitor, Sound System, Customized Podium and other Allied equipment for various Classrooms at NIA, Pune.

Dear Sir,

We, the undersigned, hereby submit our Technical Proposal against your Request for Proposal floated vide RFP Ref: NIA/ENGG/AV-009 dated 06.11.2023.

We hereby declare that all the information and statements made in this Technical bid are true and accept that any misinterpretation contained in it may lead to our disqualification.

We hereby declare that if price of any item is disclosed by us in the Technical Bid, it may lead to our disqualification.

We undertake, if our Proposal is accepted, to initiate the Implementation services related to the assignment not later than the date indicated in Fact Sheet.

We agree to abide by all the terms and conditions of the RFP document. We would hold the terms of our bid valid for as stipulated in the RFP document.

We understand, you are not bound to accept any Proposal you receive.

Yours sincerely,

Authorized Signature [*In full and initials*]: \_\_\_\_\_

Name and Title of Signatory: \_\_\_\_\_

Name of Firm: \_\_\_\_\_

Address: \_\_\_\_\_

Location: \_\_\_\_\_ Date: \_\_\_\_\_

**Form-4: Pre-Bid Queries Format**

(To be filled by the Bidder)

**Name of the Company/Firm:**

\_\_\_\_\_

Bidding document Fee Receipt No \_\_\_\_\_

**Person(s) Representing the Company/ Firm:**

Name of the Person	Designation	Email-ID(s)	Tel. Nos. & Mobile Nos.

**Company/Firm Contacts:**

Contact Person(s)	Address for Correspondence	Email-ID(s)	Tel. Nos. & Fax Nos.

**Query/Clarification Sought: (MS-Excel Sheet Format)**

S.N.	BidderName	RFP ChapterNo.	RFP ClauseNo.	RFP Page No.	Clause Details as per RFP	Query/ Clarification / Suggestion

**Note:** Queries must be strictly submitted only in the prescribed format (.XLS/ .XLSX/.PDF). Queries not submitted in the prescribed format will not be considered / responded at all by the tendering authority. Also, kindly attach the coloured scanned copy of the receipt towards the submission of the bid document fee. Also, the bidders having purchased the tender / RFP document will only be responded to i.e., their pre-bid queries will be entertained and responded. Also, the soft copy of the queries (**only in MS-Excel Sheet format**) should also be submitted through e-mail at.

[pvveer@niapune.org.in](mailto:pvveer@niapune.org.in), [amol@niapune.org.in](mailto:amol@niapune.org.in), [sridharjayashree@niapune.org.in](mailto:sridharjayashree@niapune.org.in).

**Form 5: Undertaking on Authenticity of AV Hardware & peripherals**

**(To be filled by the bidder (On ₹.100/- Non-judicial stamp paper))**

To,

The Director  
National Insurance Academy  
25, BalewadI, Baner Road,  
NIA Post Office,  
Pune - 411045

Reference: NIA/ENGG/AV-010 dated 01.08.2024

This has reference to the items being supplied / quoted to you vide our bid ref. no.: NIA/ENGG/AV-010 dated 01.08.2024

We hereby undertake that all the components / parts / assembly / software used in the equipment shall be genuine, original and new components / parts / assembly / software from respective OEMs of the products and that no refurbished / duplicate / second hand components / parts / assembly / software are being used or shall be used. In respect of licensed operating system, we undertake that the same shall be supplied along with the authorized license certificate with our name / logo. Also, that it shall be sourced from the authorized source for use in India.

In case, we are found not complying with above at the time of delivery or during installation, for the equipment already billed, we agree to take back the equipment already supplied at our cost and return any amount paid to us by you in this regard and that you will have the right to forfeit our PBG for this bid or debar / black list us or take suitable action against us.

Authorized Signatory

Name:

Designation:

**Form-6: Bidder's Authorization Certificate**

(To be filled by the Bidder)

To,

The Director  
National Insurance Academy  
25, Balewad I, Baner Road,  
NIA Post Office,  
Pune - 411045

I/ We {Name/ Designation} hereby declare / certify that {Name / Designation} is hereby authorized to sign relevant documents on behalf of the company / firm in dealing with RFP reference No. NIA/ENGG/AV-010 dated 01.08.2024. He/ She is also authorized to attend meetings & submit technical & commercial information/ clarifications as may be required by you in the course of processing the Bid. For the purpose of validation, his/ her verified signatures are as under.

Thanking you,

Name of the Bidder: -

Verified Signature

Authorized Signatory:

Seal of the Organization:

Date:

Place:

## **Form 7: Performance Bank Guarantee (PBG) - Template**

To,  
The Director  
National Insurance Academy  
25, Balewad I, Baner Road,  
NIA Post Office,  
Pune - 411045

Whereas, << name of the supplier and address >> (hereinafter called “the Bidder”) has undertaken, in pursuance of contract no. << insert contract no. >> dated. << insert date >> to provide Implementation services for << name of the assignment >> to NIA (hereinafter called “the beneficiary”)

And whereas it has been stipulated in the said contract that the Bidder shall furnish you with a bank guarantee by a recognized nationalised bank for the sum specified therein as security for compliance with its obligations in accordance with the contract;

And whereas we, << name of the bank >> a banking company incorporated and having its head / registered office at << address of the registered office >> and having one of its office at << address of the local office >> have agreed to give the supplier such a bank guarantee.

Now, therefore, we hereby affirm that we are guarantors and responsible to you, on behalf of the supplier, up to a total of ₹.<< insert value >> (Rupees << insert value in words >> only) and we undertake to pay you, upon your first written demand declaring the supplier to be in default under the contract and without cavil or argument, any sum or sums within the limits of Rs .<< insert value >> (Rupees << insert value in words >> only) as aforesaid, without your needing to prove or to show grounds or reasons for your demand or the sum specified therein.

We hereby waive the necessity of your demanding the said debt from the Bidder before presenting us with the demand.

We further agree that no change or addition to or other modification of the terms of the contract to be performed there under or of any of the contract documents which may be made between you and the Bidder shall in any way release us from any liability under this guarantee and we hereby waive notice of any such change, addition or modification.

This Guarantee shall be valid until << Insert Date >>) Notwithstanding anything contained herein:

- I. Our liability under this bank guarantee shall not exceed ₹. << insert value >> (rupees << insert value in words >> only).
- II. This bank guarantee shall be valid up to << insert expiry date >>)
- III. It is condition of our liability for payment of the guaranteed amount or any part thereof arising under this bank guarantee that we receive a valid written claim or demand for payment under this bank guarantee on or before << insert expiry date >>) failing which our liability under the guarantee will automatically cease.

(Authorized Signatory of the Bank) Seal:

Date:

**Form 8: RFP Form***(To be filled by the Bidder)*

<b>Name of the Tendering Authority</b>	
<b>Address</b>	
<b>Telephone</b>	
<b>Mobile No</b>	
<b>Email</b>	

**Firm Details:**

<b>Name of Firm</b>				
<b>Name of CMD of the firm with email id,contact number</b>				
<b>Name of Contact Person with Designation</b>				
<b>Registered Office Address</b>				
<b>Address of the Firm</b>				
<b>Year of Establishment</b>				
<b>Type of Firm Put Tick ( √ ) mark</b>	Public Limited	Private Limited	Partnership	Proprietary
<b>Telephone Number(s)</b>				
<b>Email Address /Web Site</b>	Email:		Web-Site:	
<b>Fax No.</b>				
<b>Mobile Number</b>	Mobile:			
<b>Certification / Accreditation / Affiliation if Any</b>				

The requisite tender fee amounting to Rs.1180.00 (Rupees <in words>) has been deposited vide receipt no. \_\_\_\_\_ Dated \_\_\_\_\_.

We agree to abide by all the terms and conditions mentioned in this form issued by the Empanelment Authority and also the further conditions of the said notice given in the attached sheets (all the pages of which have been signed by us in token of acceptance of the terms mentioned therein along with stamp of the firm).

Date:

Name &amp; Seal of the firm:

Authorized Signatory:

**Form-9: Covering Letter - Technical Bid**

(To be filled by the bidder and signed in Company Letter Head)

To,

The Director  
National Insurance Academy  
25, Balewadi, Baner Road,  
NIA Post Office,  
Pune - 411045

**Subject:** Technical Proposal for Selection of Agency for the tender under reference no. NIA/ENGG/AV-010 dated 01.08.2024

Sir,

We, the undersigned, offer to provide our services against your RFP enquiry no. NIA/ENGG/AV-010 dated 01.08.2024

<Insert RFP no> dated <insert date>. We are hereby submitting our Proposal, which includes this Technical Bid.

We hereby declare that all the information and statements made in this Technical bid are true and accept that any misinterpretation contained in it may lead to our disqualification.

We agree to abide by all the terms and conditions of the tender document. We would hold the terms of our bid valid for as stipulated in the RFP document.

We agree that you are not bound to accept the lowest or any bid response you may receive. We also agree that you reserve the right in absolute sense to reject all or any of the products / services specified in the bid response without assigning any reason whatsoever.

It is hereby confirmed that I/We are entitled to act on behalf of our corporation/company /firm/organization and empowered to sign this document as well as such other documents which may be required in this connection.

Yours sincerely,

Authorized Signature [In full and initials]:

Name and Title of Signatory:

**Form 10: Manufacturer's Authorization Form (MAF)**

Letter No.

To,

The Director  
National Insurance Academy  
25, Balewadi, Baner Road,  
NIA Post Office,  
Pune - 411045

Sub: OEM Authorization Letter

Dear Sir,

We, who are established and reputable-----  
-----having factories / development facilities at  
(address of-----factory / facility) do hereby authorize M/s. (Name and  
address of Agent) to submit a Bid and accept the Purchase Order against the above Bid Invitation.  
We hereby extend our full guarantee and warranty for the Solution, Products and services offered  
by the above firm against this Bid Invitation. We further undertake that we will support the supplier  
will all related spares and maintenance during the entire contract period.  
We duly authorize the said firm to act on our behalf in fulfilling all installations, technical support  
and maintenance obligations required by the Project.

Yours faithfully,

Name

Seal

**Note: This letter of authority should be on the letterhead of the OEM and should be signed  
by a person competent and having the power of attorney to bind the manufacturer.**



**Form-11: Financial Bid Cover Letter and Format**

**{Bid Price not be disclosed in Technical Bid}**

(To be filled by the bidder and signed in Company Letter Head)

To,

The Director  
National Insurance Academy  
25, Balewad I, Baner Road,  
NIA Post Office,  
Pune - 411045

**Subject:** Submission of the financial bid for Selection of Agency for Supply and Installation of integrated solution of LED Display, Interactive Touch Monitor, Sound System, Customized Podium and other Allied equipment for various Classrooms at NIA, Pune.

Dear Sir,

We, the undersigned, offer to Supply and Installation of integrated solution of LED Display, Interactive Touch Monitor, Sound System, Customized Podium, and other Allied equipment for various Classrooms at NIA, Pune. vide RFP. No. NIA/ENGG/AV-009 dated 06.11.2023 and our Proposal (Pre-qualification, Technical and Financial Proposals). Our attached Financial Proposal is for the sum of <<Amount in words and figures>>inclusive of taxes and duties.

**1. Price and Validity**

All the prices mentioned in our RFP are in accordance with the terms as specified in the RFP documents. We declare that our Bid Price is for the entire scope of the work as specified in the appropriate section in the RFP. All the prices and other terms and conditions of this Bid are valid minimum for a period from the date of opening of the Bid. Subject to further extended period as mutually agreed upon.

We hereby confirm that our prices do not include any taxes and duties.

We understand that the actual payment would be made as per the existing tax rates during the time of payment.

**2. Unit Rates**

We have indicated in the relevant forms enclosed, the unit rates for the purpose of on account of payment from the scope of work under the contract.

**3. Qualifying Data**

We confirm having submitted the information as required by you in your Instruction to Bidders. In case you require any other further information/documentary proof in National Insurance Academy (NIA) this regard before evaluation of our bid, we agree to furnish the same in time to your satisfaction.

**4. Bid Price**

We declare that our Bid Price is for the entire scope of the work as specified in the RFP. These prices are indicated at Price Bid attached with our bid as part of the Bid. We understand you are not bound to accept any tender you receive.

We hereby declare that our bid is made in good faith, without collusion or fraud and the information contained in the bid is true and correct to the best of our knowledge and belief.

We understand that our bid is binding on us and that you are not bound to accept a bid you receive.

Thanking you,

We remain,

Yours sincerely,

Authorized Signature:

Name and Title of Signatory:

Name of Firm:

Address:

**Form-12: Self-Declaration**

(Non-blacklisted in company Letter Head)

To,

The Director  
National Insurance Academy  
25, Balewad I, Baner Road,  
NIA Post Office,  
Pune - 411045

In response to the NIA/ENGG/AV-009 dated 06.11.2023, for RFP titled Supply and Installation of integrated solution of LED Display, Interactive Touch Monitor, Sound System, Customized Podium and other Allied equipment for various Classrooms at NIA, Pune.

I/ We hereby declare that presently our Company/ firm is not under declaration of ineligible for corrupt & fraudulent practices, blacklisted either indefinitely or for a particular period of time, or had work withdrawn, by any State/ Central government/ PSU.

I/We further declare that there is no past / ongoing legal trial in name of any of the Owner / Partner / Director of the bidding company as on the tender submission date.

If this declaration is found to be incorrect then without prejudice to any other action that may be taken, my/ our security may be forfeited in full and the tender if any to the extent accepted may be cancelled.

Thanking you,

Name of the Bidder: ..... Authorized Signatory:

Signature:

Seal:

Date:

Place:

## **Instruction for Online Bid Submission**

Tender wizard portal is the complete process of e-Tendering, from publishing of tenders online, inviting online bids, evaluation of bids using the system. You may keep a watch of the tenders floated under <https://www.tenderwizard.com/NIA>.

More information useful for submitting online bids on the tender-wizard portal may be obtained at: <https://www.tenderwizard.com/NIA>.

**Bidders please note that they need to upload scanned copies of all the required documents and all Forms from Form 1 to Form 12 as indicated in the RFP Document.**

### **Preparation of Bids**

- a. Bidder should take into account any corrigendum published on the tender document before submitting their bids.
- b. Please go through the tender advertisement and the tender document carefully to understand the documents required to be submitted as part of the bid.
- c. Bidder, in advance, should get ready the bid documents to be submitted as indicated in the tender document / schedule and generally, they can be in PDF formats. Bid Original documents may be scanned with 100 dpi with colour option which helps in reducing size of the scanned document.
- d. To avoid the time and effort required in uploading the same set of standard documents which are required to be submitted as a part of every bid, a provision of uploading such standard documents (e.g., PAN card copy, GST, Annual reports, auditor certificates etc.) has been provided to the bidders. Bidders can accordingly upload such documents.
- e. The server time (which is displayed on the bidders' dashboard) will be considered as the standard time for referencing the deadlines for submission of the bids by the bidders, opening of bids etc. The bidders should follow this time during bid submission.
- f. The uploaded bid documents become readable only after the tender opening by the authorized bid openers.
- g. Upon the successful and timely submission of bid click "Complete" (i.e., after Clicking "Submit" in the portal), the portal will give a successful Tender submission acknowledgement & a bid summary will be displayed with the unique id and date & time of submission of the bid with all other relevant details.



**NATIONAL INSURANCE ACADEMY  
BALEWADI, PUNE 411045.**

**Tender No.: NIA/ENGG/AV-010 dated 01.08.2024**

**Name of Work : eTender of RFP FOR DESIGN , SUPPLY AND INSTALLATION OF  
AV EQUIPMENT FOR HYBRID ( SMART CLASSROOMS) AT NIA PUNE.**

**FINANCIAL BID FORM**

**Name of the Firm/Bidders**

**NIA**

<b>Sr. No.</b>	<b>Item Description</b>	<b>Quantity</b>	<b>Unit</b>	<b>Make</b>	<b>Model</b>	<b>Unit Rate (in ₹.)</b>	<b>Total Basic Price (in ₹.)</b>	<b>GST %</b>	<b>GST Amount (in ₹.)</b>
1	Supply and Installation of 98" ULTRA HD 4K LED INTERACTIVE DISPLAY	2	No				0.00		0.00
2	Supply and Installation of WALL MOUNT KIT FOR 98" LED DISPLAY	2	No				0.00		0.00
3	Supply and Installation of 55" Professional Display (LFD)	2	No				0.00		0.00
4	Supply and Installation of WALL MOUNT KIT for 55" LED Display with Swivel	2	No				0.00		0.00
5	Supply and Installation of Camera for Presenter with Mount	2	No				0.00		0.00
6	Supply and Installation of Camera for Students with Mount	4	No				0.00		0.00

7	Supply and Installation of Camera Mixer	2	No				0.00		0.00
8	Supply and Installation of Capture Card	2	No				0.00		0.00
9	Supply and Installation of Surface Mounting Ceiling Microphone including required Mount	2	No				0.00		0.00
10	Supply and Installation of Headworn Microphone	2	No				0.00		0.00
11	Supply and Installation of Lavalier Microphone	2	No				0.00		0.00
12	Supply and Installation of Handheld Microphone	8	No				0.00		0.00
13	Supply and Installation of 12 Channel Mixing Console	2	No				0.00		0.00
14	Supply and Installation of DSP with AEC	2	No				0.00		0.00
15	Supply and Installation of On-Wall Powered Speakers	6	Pairs				0.00		0.00
16	Supply and Installation of USB - C 4 X 3 MATRIX SWITCHER	2	No				0.00		0.00
17	Supply and Installation of HDMI Transmitter	6	No				0.00		0.00
18	Supply and Installation of HDMI Receiver	6	No				0.00		0.00
19	Supply and installation of 6X button panel to trigger events in control configurations	2	No				0.00		0.00
20	Supply and installation of Cable Cubby Passthrough	2	No				0.00		0.00
21	Supply and Installation of USB-C Cable – 3 M	2	No				0.00		0.00
22	Supply and Installation of High-Speed HDMI Cable - 2 M	14	No				0.00		0.00

23	Supply and Installation of High-Speed HDMI Cable - 3 M	6	No				0.00		0.00
24	Supply and Installation of 10 M HIGH SPEED HDMI AOC CABLE	4	No				0.00		0.00
25	Supply and Installation of USB 3.0 A (M) to B (M) Cable - 3.00 M	6	No				0.00		0.00
26	Supply and Installation of Audio Cable, Speaker Cable, CAT6 UTP Cable as per site requirement	2	Lot s				0.00		0.00
27	Supply and Installation of Digital podium with Built in minimum 21" Interactive Display and space for gooseneck microphone.	2	No s				0.00		0.00
28	Supply and Installation of USB 3.0 Active Extender Cable 10 M	2	No s				0.00		0.00
29	Supply and Installation of Compact Wireless Microphone System	4	No s				0.00		0.00
30	Supply and Installation of various Cables, Connectors and accessories required for integration of above equipments.	2	Lot s				0.00		0.00
31	Supply and Installation of Managed 08 Port PoE / PoE+ switch as per site requirement	2	No s				0.00		0.00
32	Supply and Installation of Equipment Rack with require no of power sockets.	2	No s				0.00		0.00
	<b>Total Amount</b>						0.00		0.00
	<b>OPTION I - NET TOTAL INCLUDING GST</b>						<b>0.00</b>		

Sr. No.	Item Description	Quantity	Unit	Make	Model	Unit Rate (in ₹.)	Total Basic Price (in ₹.)	GST %	GST Amount (in ₹.)
1	Supply and Installation of CAMERA FOR PRESENTER: SRG-A12 with PTZ Auto Framing Revolutionary PTZ AUTO Framing Technology powered by built in AI analytics ensuring high quality composed shots without operator	2	No	Sony	Sony SRG-A12		0.00		0.00
2	Supply and Installation of CAMERA FOR STUDENTS: SRG-A12 with PTZ Auto Framing Revolutionary PTZ AUTO Framing Technology powered by built in AI analytics ensuring high quality composed shots without operator	2	No	Sony	Sony SRG - X40 UH		0.00		0.00
	<b>Total Amount</b>						0.00		0.00
	<b>OPTION I - NET TOTAL INCLUDING GST</b>						<b>0.00</b>		
	<b>OPTION I EXCLUDING COST OF CAMERAS FOR PRESENTER AND STUDENTS</b>						0.00		0.00
	<b>TOTAL OF OPTION I EXCLUDING COST OF CAMERAS FOR PRESENTER AND STUDENTS</b>						<b>0.00</b>		
	<b>TOTAL OF OPTION II INCLUDING ABOVE</b>						<b>0.00</b>		



	<b>TWO CAMERAS</b>	<b>SONY</b>						
--	------------------------	-------------	--	--	--	--	--	--

**NOTE:**

1. Soft Copies of brochures / leaflets of each equipment needs to be uploaded in Technical Bid.
2. Please fill in make and model of equipment / item in respective blue cell above.
3. Please fill in unit cost and GST amount of each equipment in blue cell above.
4. Total unit Cost and Total Amount of each item will appear automatically.
5. Total Amount will appear automatically.
6. In case of any discrepancy between Unit Price & Total Price, the Unit Price will prevail.
7. Bidder shall quote for all the items. The order will be placed on turnkey basis and will not be splitted. Bidder shall quote only one option/brand for each item. Multiple options/brands quoted may disqualify the bidder

1. Uploading of Soft Copies of brochures / leaflets of each equipment as stated above needs to be uploaded in Technical Bid.

2. Please fill in make and model of equipment / item in respective blue cells only.

3. Please fill in unit rate and GST percentage (%) for each equipment in blue cell above.

4. Total Amount of each item will appear automatically.

5. Total Amount of each item and GST amount will appear automatically.

6. In case of any discrepancy between Unit Price & Total Price, the Unit Price will prevail.

7. Bidder must quote for all the items of Option I including Option II for Sony Cameras.

8. The order will be placed on turnkey basis and will not be splitted.

9. Bidder shall quote only one option/brand for each item. Multiple options/brands quoted may disqualify the bidder

Vendor has to Enter the Full Company Name

Vendor has to Quote In Blue Colour Cell Only

The Vendor has to Quote Item rate for Individual items.

"This is Electronic Spread Sheet Signature Is Not Required"